

66
October
1988

elektor **INDIA** electronics

Rs. 8.00

THE PRACTICAL MAGAZINE WITH THE PROFESSIONAL APPROACH

Temperature-controlled soldering iron •
Fast NiCd charger •
VIDEO THEATRES •



Publisher: C.R. Chandarana
Editor: Surendra Iyer
Technical Adviser: Ashok Dongre
Circulation: J. Dhas
Advertising: B.M. Mehta
Production: C.N. Mithagari

Address:
 ELEKTOR ELECTRONICS PVT. LTD.
 52, C Proctor Road, Bombay-400 007 INDIA
 Telex: (011) 76661 ELEK IN

Overseas editions:

Elektor Electronics
 1, Harlequin Avenue,
 Great West Road, Brentford TW8, SEW U.K.
Editor: Len Seymour

Pultron Publicacoes Tecnicas Ltda
 Av Ipiranga 1100, 9º andar CEP 01040 Sao Paulo - Brazil
Editor: Juliano Barsali

Elektor sari
 Route Nationale, Le Seau; B.P. 53
 59270 Bailleul - France
Editors: D R S Meyer;
 G C P Ruedersdorf

Elektor Verlag GmbH
 Susterfeld-Strasse 25 100 Aachen - West Germany
Editor: E J A Kreppeisauer

Elektor EPE
 Karaiskaki 14 16673 Voula - Athens - Greece
Editor: E Xanthoulis

Elektuur B.V.
 Peter Trackpoelstraat 2.4
 6191 VK Beek - the Netherlands
Editor: P E L Kersemakers

Ferreira & Bento Lda
 R.D. Estefania, 32.1º 1000 Lisboa - Portugal
Editor: Jorge Goncalves

Ingelak S.A.
 Plaza Republica Ecuador 2.28016 Madrid-Spain
Editor: A M Ferrer

In Part:
 Kedhorn Holdings PTY Ltd Cnr Fox Valley Road &
 Kingle Street Wahroonga NSW 2076 - Australia
Editor: Roger Harrison

Electronic Press AB
 Box 63
 182 11 Danderyd - Sweden
Editor: Bill Cedrum

The Circuits are domestic use only. The submission of designs or articles implies permission to the publisher to alter and translate the text and design and to use the contents in other Elektor Publications and activities.

The publishers cannot guarantee to return any material submitted to them. Material must be sent to the Holland address (given above). All drawings, photographs, printed circuit boards and articles published in elektor publications are copyright and may not be reproduced or imitated in whole or part without prior written permission of the publishers.

Patent protection may exist in respect of circuit devices, components etc. described in this magazine.

The publishers do not accept responsibility for failing to identify such patent or other protection.



MEMBER

Printed at : Trupti Offset
 Bombay - 400 013

Ph. 4923261, 4921354
 Copyright © 1988 Elektuur B.V.

Suresh Singh

CONTENTS

| | |
|-------------------------------------------------------------------------|-------|
| Editorial | |
| Open systems at crossroads ? | 10.05 |
| Audio & Hi-Fi | |
| PROJECT: Microphone preamplifier with active filter | 10.35 |
| Components | |
| A high-speed depletion-mode DMOS FET for small-signal application | 10.32 |
| Computers | |
| PROJECT: 64 Kbyte static RAM extension for MSX computers | 10.22 |
| Shielding computers with metal-coated glass | 10.26 |
| General Interest | |
| PROJECT: Motorphone | 10.52 |
| PROJECT: Fast NiCd charger | 10.44 |
| PROJECT: Temperature-controlled soldering iron | 10.38 |
| Sine-square-triangle generator | 10.54 |
| Radio & Television | |
| PROJECT: Microprocessor-controlled radio synthesizer - 2 | 10.47 |
| Computer-generated colour test chart | 10.53 |
| Test & Measurement | |
| PROJECT: Self-inductance meter | 10.28 |
| Information | |
| Video Theatres (Entertainment Revolution) | 10.21 |
| Telecommunication news | 10.14 |
| Electronics news | 10.17 |
| Appointments | 10.69 |
| New products | 10.60 |
| Corrections | 10.74 |
| Guide Lines | |
| Classified advertisements | 10.73 |
| Index of advertisers | 10.74 |
| Selex - 38 | |
| Ohm-Adapter | 10.56 |

OPEN SYSTEMS AT CROSSROADS?

When early last year it was announced that a group of major European and American computer manufacturers, the X/Open Group, had agreed to adopt AT&T's UNIX operating system as an industry standard, it seemed that we were at last moving towards an open standard of sorts. But, alas, these intentions are in danger of going the same way as those of the makers of MSX machines: to Never Never Land.

A number of the X/Open Group participants, among them IBM, DEC, Siemens, and Honeywell Bull, have accused AT&T of attempting to influence developments in computer hardware by using UNIX as a lever. They also claim that certain computer companies in which AT&T has a stake, particularly Sun Microsystems, are given advance notice and the opportunity of influencing future versions of UNIX.

AT&T, backed by Unisys, the world's second largest computer manufacturer, ICL, and Xerox, says that all it is trying to do is to unify the many different variants of UNIX into one consistent system that will allow all computers running it to be fully interoperational.

While AT&T maintains that it is fully committed to keeping UNIX open and giving all computer manufacturers unbiased access to future versions of UNIX, the dissenting companies claim that they have been refused to lend a hand in the development of UNIX, although Sun is doing so.

This whole rumpus is, of course, about money — lots of money. Dataquest, the US market research organization, estimates that the world computer market will amount to some \$ 11 billion by 1992 and to perhaps more than \$ 20 billion by the mid-1990s. Already, UNIX has more than five per cent of this market, and this share is likely to grow to over ten per cent by 1992. That would put AT&T in a very strong position to influence hardware development.

Since AT&T has apparently not agreed to grant the dissenting companies the same facilities as Sun, these manufacturers, led by Hewlett Packard and IBM, have set up Open Software Foundation. They claim that this non-profit making organization, in which they have invested hundreds of millions of dollars, is intended to develop a new version of UNIX that will not be under the control of AT&T, but will be truly open.

Although this would seem to indicate (encouragingly for users the world over) that the major manufacturers are converging on an open system that their customers have been clamouring for since the early 1980s, are we right in being optimistic? After all, the X/Open Group is not dead. In fact, IBM has only just joined the 15 manufacturers, including AT&T and Unisys, that participate in this group. So, there are now two powerful groups of major computer manufacturers (seven of whom belong to both groups) whose aim it is to promote UNIX as a common standard. But which UNIX?

Users the world over can only hope that the two groups will be able to bury the hatchet soon and together produce a universal operating system.

Front cover

A scientist at Bristol Polytechnic's Transputer Centre illustrates the transputer's capabilities in solving the Mandelbrot Set, sometimes described as the most complicated object in mathematics. Bristol Polytechnic's Transputer Centre has been set up to carry out research and development on uses of the transputer in industry, help companies to exploit the parallel processing potential of the transputer, and to train students and personnel in its use.

VIDEO THEATRES

Entertainment Revolution

An entertainment electronic revolution, virtually gone unnoticed so far and holding the potential of sweeping the country, has already been ushered in. The introduction of video theaters has not been heralded with any fanfare and if knowledge of its existence and potential is still poor, it is mainly because it is rooted in smaller towns and mofussil areas. Paradoxically, the video theater seeds have been sown in the countryside and not in the metropolitan cities as is the wont of those testing markets of electronic products. Except for the video theaters, almost every electronic innovation has been introduced in large, commercial cities.

"It may sound unusual that a technology of such magnitude should have a beginning in smaller towns", says Mr S.C. Hira the pioneer in the Indian Video Field who gave this country its first video feel. Some ten years ago, Hira's Esquire ushered in video in India through his factory at the Santacruz Electronic Export Processing Zone (SEEPZ). The justification of propagating video theaters in mofussil areas is that the medium is most suited to small towns where cinemas are in great demand but the halls screening them are far fewer.

Video theaters will transform audiences for the cinema. "You will see how dramatic this transformation is when the triumph of this technology is exquisite" points out Hira. He admits to considerable interest among prospective cinema theater owners in installing video projection systems. While it is unlikely that the existing owners of conventional theaters will convert to the video technology, the new proprietors of cinema might favour videos right at the beginning.

The advantage of operating a video system in a cinema theater is manifold. Firstly the operator has only to insert a video film into the projection equipment system and not the messy 35 mm films in cans. The running cost is much cheaper because of lower power consumption, easier maintenance, cheaper price for video compared with that for the 35 mm software and a smaller manpower complement. Above all, the system is longer lasting and provides a relatively trouble-free service.

In several parts of the world, video theaters have already gained much popularity. Entry of Esquire with the

backing of well-known National of Japan, video theater technology is set for a major breakthrough. A few other parties, including the one in Madras in South, have offered a similar technology and path has been cleared for more competition. However, National claims to have incorporated some special features in their package said to be not available in other systems.

Most of the patronage for the video theaters now comes from Gujarat, Rajasthan and other states in North India. Although the prospective cinema theater owners have begun acquiring the video theater technology neither have they advertised their projects nor have the suppliers in Bombay commenced aggressive marketing strategy. Perhaps everyone is watching the other and adopting a cautious attitude to business. However, the technology has been well adopted in several parts of the world. India is one of the last few nations to go in for the video theaters.

The National technology being adopted by Esquire following the latter's receipt of a letter of intent in April this year is capable of enlarging the picture on a screen six times the normal Television size. The magnification does not blur the picture and the resolution is considered as good, and even better, than the conventional cinema in regular theatres. The technology is ideal for community viewing. A video projector connected to a VCR can be used for either showing a recorded programme or Doordarshan telecast programme through the VCR's tuners.

The video projection systems (VPS) for enlarged screenings of video films is expected to gain in popularity in coming years for also receiving government sponsored programmes for rural developments, eradication of poverty, propagation of family welfare and mass communication through Doordarshan's regional and network programme. Video projectors, in contrast with conventional movie projectors, require less infrastructure in terms of capital investment, land and building, power and maintenance. Besides the running cost is virtually negligible and the tape itself available cheap, the video option for many cinema owners is a strong one. The audience capacity in these theatres will be ideally 15 to 200. For the view-

ers in terms of eye strain, it will be the same as watching TV. Moreover, there will be a lifelike image projected on the screen. The projection room space requirement is also less in that the VPS takes very little room and is installed in the theater itself, between the audience and the screen to be precise. The reproduction of colours on the screen will be the same as on TV and three primary colour emitting lamps in the VPS takes care of all combinations. Unlike the TV, however, it will be necessary to switch off the light during the screening. How low is the power consumption is borne out by the fact that a three-hour projection will involve only one unit of current against some 12 units in conventional cinema.

Several innovations are possible on the tape itself at the editing table. Extra and special effects can be provided by manipulating the tape, cutting scenes and rejoining them at predetermined sequences. Portions erased could be restored. The medium thus lends itself to endless experimentation.

In due course, films for the VPS might just as well be shot in video camera making the entire project far cheaper. Currently, the film processing laboratories cost a lot for additional prints. Much of this cost can be obviated by shooting on video films and re-shooting by erasing the earlier sequence if the shot is not well taken. The entire equipment is also mobile. It can be packed and carried easily from one venue to another. Anybody with space for screening the VPS could hire out the equipment. It is also possible for corporate agencies to acquire the equipment on lease for projecting the product profile or for training of manpower.

Video theatres might even push out cinema from the strongholds in cities. This possibility is attributable to the limited availability of theaters.

There are some 6,800 cinema houses spread over 3,200 towns in India with the seating capacity ranging from 300 to 1,050. Of these 50 per cent are in the Southern region, 19 per cent of the remaining in the western region and 12 per cent in the eastern region. In addition there are some 4,500 touring cinemas. These and the many towns with populations of 5,000 and 20,000 currently not served by cinema are potential patrons of the VPS.

64 KBYTE STATIC RAM EXTENSION FOR MSX COMPUTERS

Although the concept of MSX allows the addressing of up to 1 Mbyte of memory, the number of computers that use more than 128 Kbyte is surprisingly low, and ready-made RAM extension modules thin on the ground. We decided to do something about this, and developed a plug-in RAM extension that enables MSX users to increase the total available memory of the computer in steps of 32 or 64 Kbyte.

With a mere 64 Kbyte installed as a standard, and 128 Kbyte available on newer models only, MSX computers do not follow the trend towards the use of vast amounts of system memory. The diagram of Fig. 1 shows the theoretical memory structure of the MSX concept, which was originally designed for 1 Mbyte of addressable memory. In practice, however, there is not a single MSX computer that actually uses all of the available system memory.

In principle, any MSX computer can have up to four so-called *primary slots*, which are, in turn, subdivided into four blocks of 16 Kbyte. The BASIC and system ROM are located in the address range of the first slot (number 0). The two ROMs use up half the memory in this, occupying address range 0000h to 7FFFh, i.e., two blocks of 32 Kbyte. Random access memory is usually located in another slot, and in address range 8000h to FFFFh. After a reset, the control system runs a test routine to examine which slots hold RAM.

A slot can be *expanded* with the aid of additional hardware. Slot expansion makes it possible to use four equal banks per slot. Like the slot itself, these banks are in principle composed of four blocks of 16 Kbyte. In practice, a slot expander circuit enables extending the memory capacity of a primary slot from 64 to 256 Kbyte.

Table 1 lists the slot structure of a number of MSX computers, and also shows which slots are expanded internally. The function of the so-called *memory mapper* in MSX-2 machines can be disregarded as far as the present RAM extension card is concerned. Most MSX computers have one or two non-expanded slots, so that 64 or 128 Kbyte of RAM can be added without problems.

More memory, more workspace?

When running in BASIC, MSX com-

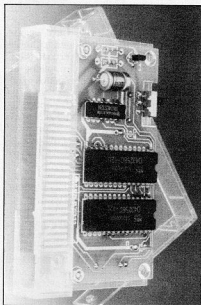

puters have relatively little free memory — in practice, this hardly ever amounts to more than 23 Kbyte. It may come as a surprise that adding 128 Kbyte of RAM does not resolve this limitation, since BASIC can not address this additional memory. Does this make any RAM extension useless? Fortunately, the answer is no. Evidently, the present circuit would not have been developed if the computer could not benefit from it. There are programs capable of using the extra memory by bypassing the memory handling routines in MSX BASIC. Still other programs can only work when additional memory is installed, and the above limitations of BASIC are, of course, unknown when machine code is used.

In a number of cases, the RAM extension card described makes it possible to run older programs on more recently introduced computers. This is because the first releases of some programs did not

assume that the 64 Kbyte of memory was divided over several slots. This, however, is not strictly required according to the MSX standard. In the case of the present RAM extension, this rule is, of course, observed.

In BASIC, the extension card offers an interesting feature by allowing memory to be made 'read-only' for testing whether a machine code or BASIC program can run from EPROM. Programs developed by the user and intended for storing in EPROM can, therefore, be tested in RAM, obviating the need to clear and load EPROMs for every minor change in the program (an EPROM programmer for MSX computers was described in ⁽¹⁾).

Because the internal memory is nearly always in a 'high' slot number, the control system does not encounter it until all other slots have been examined for the presence of RAM. The control system uses the first RAM bank found. Testing is done in blocks of 16 Kbyte, i.e., in the areas C000h through FFFFh, and 8000h through BFFFh. This means that the 32 Kbyte RAM may be divided over two slots.

When a lower slot is selected, the control system will find the extension card before it finds the internal one, and use it as workspace. When, for example, the internal memory is located in slot 3, the RAM extension can be used in slots 0, 1 and 2. The slot allocation of the internal memory is given in Table 1 for a number of commonly used MSX micros. For a computer not listed, consult the technical reference manual supplied with it. The internal RAM is always selected when it is in slot #0 or #1.

Circuit description

The circuit diagram of the RAM extension card is given in Fig. 2. Composed of only two 32 Kbyte static RAM chips, one CMOS IC, two resistors, three capacitors and one FET, the memory extension could hardly be simpler. Connector K₁ is formed by the (pretinn-

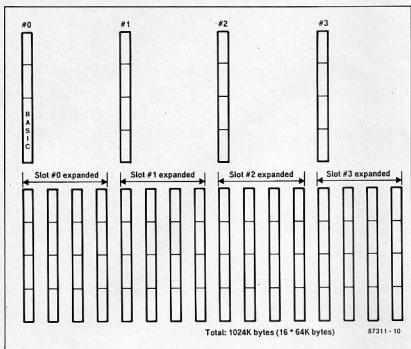

Fig. 1. Theoretical memory structure of MSX computer.

Table 1

Slot assignment of MSX computers

| MSX1 | RAM-SLOT | REMARKS |
|---------------------|----------|-------------------------------------------------------------------------------------|
| AVT Daewoo DPC-200 | 1 | |
| Canon V20 | 3 | |
| Goldstrat FC 200 | 2 | |
| JVC HC-7-gb | 2 | |
| Mitsubishi MFL-FX1 | 3-2 | Slot 3 expanded, 64 Kb RAM |
| Mitsubishi MFL-48 | 0 | 32 Kb RAM |
| Mitsubishi MFL-80 | 1 | |
| Panasonic CF2700 | 1 | |
| Philips VG8020 | 3 | |
| Philips VG8010 | 0 | 32 Kb RAM, slot 2 not usable |
| V68020/20 | 3-2 | |
| Sanyo MPC-100 | 3 | |
| Sony HB201p | 3 | 16 Kb ROM firmware in slot 0 |
| Sony HB75p | 2 | 16 Kb ROM firmware in slot 0 |
| Sony HB55p | 0 | 16 Kb RAM, 16 Kb ROM firmware in slot 0 |
| Sony HB10p | 3 | |
| Sony HB501p | 3 | |
| Spectravideo 738 | 1 | Slot 3 expanded, RS232/Diskrom |
| Spectravideo 728 | 1 | |
| Toshiba HX-10 | 2 | |
| Yamaha CX5M | 0 | 32Kb RAM |
| Yashica YC-64 | 3 | Slot 1 not usable |
| MSX2 | RAM-SLOT | REMARKS |
| AVT Daewoo CPC-300 | 0-2 | Slot 0 expanded. 128 Kb Memory mapper |
| Sony HB-F500P | 0-0-0-2 | Slot 0 expanded. |
| Sony HB-F700P | 3-3 | Slot 3 expanded. 256 Kb Memory mapper |
| Sony HB-F900P | 0-0-0-2 | Slot 0 expanded. Video digitizer |
| Sony HB-F9P | 3-2 | Slot 3 expanded. 128 Kb Memory mapper |
| Philips VG8220 | 3-2 | 16 Kb ROM firmware Slot 3 expanded. |
| Philips VG8230 | 3-2 | 16 Kb ROM firmware Slot 3 expanded. |
| Philips VG8235/8245 | 3-2 | Slot 3 expanded. Slot 3 expanded. |
| Philips VG8250/8255 | 3-2 | 128 Kb Memory mapper Slot 3 expanded. |
| Philips VG8280 | 3-2 | 128 Kb Memory mapper Slot 3 expanded. 128 Kb Memory mapper Video-digitizer |

ed) contact fingers of the double-sided, through-plated, printed circuit board. Gate N₁ combines SLTSL and MERQ to enable addressing the memory chips. Since these have a capacity of 32 Kbyte each, and SLTSL is intended for a range of 64 Kbyte, the selected address block needs to be divided in two 32 Kbyte blocks. This is accomplished by N₁ and N₄ combining true and inverted signal A15 and A15 with the output of N₁. Write protect switch S₁ blocks the WR signal for both memory chips via gate N₂.

RAMs IC₁ and IC₂ work independently, and one of them may be omitted when only 32 Kbyte of extra RAM is required.

A compact module

The construction of the RAM extension module on PCB Type 87311 is straightforward because the board is through-plated and available ready-made. Before mounting the parts, use a jig-saw to cut off the two corners beside the slot connector along the lines printed on the overlay. Do the same with the area behind S₁.

It is recommended to use good-quality IC sockets for the RAM chips, IC₁ and IC₂. Although the solder resist mask on the ready-made PCB affords protection against excess solder short-circuiting pins or closely running tracks, unexperienced constructors are well advised to work carefully here, and use a low-power soldering iron with a small tip. Switch S₁ is preferably a miniature slide type that can be fitted securely in the clearance at the rear of the PCB.

A problem may arise with MOSFET T₁. The Type BS170 may be supplied in a different enclosure under the type indication BS170P. The P version also has a different pin-out — see the circuit diagram. The component overlay of the PCB for the RAM extension is correct for the standard BS170.

Testing

The RAM extension should be tested before it is fitted in an enclosure. Figure 4 shows the listing of a test program typed in under MSX BASIC. The actual test program is machine code loaded as DATA with the aid of a POKE instruction in a FOR/NEXT loop.

Before switching the computer on, close S₁ to turn the extension card into a ROM block. After the computer has finished its initialisation, open S₁, type in or load the test program, and make sure that it addresses the right primary slot, which corresponds to the value POKED in line 130. It should be noted that the program tests the entire 64 Kbyte space. When the RAM extension functions correctly, the program shows the message MEMORY OK in the top left-hand corner of the screen. When

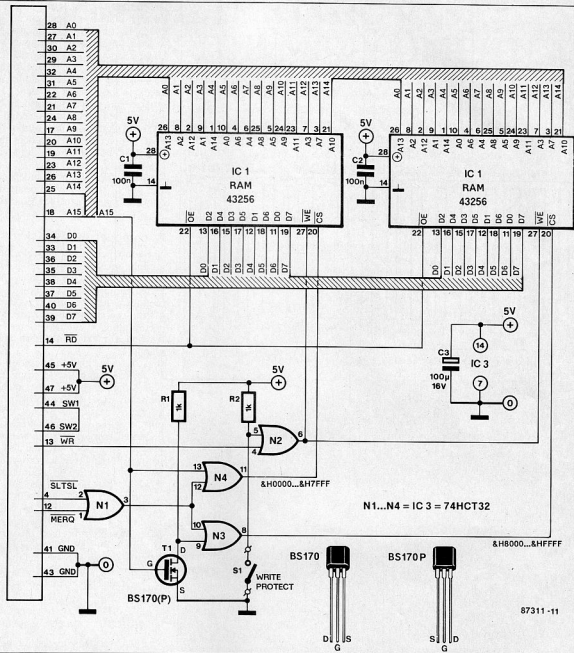

Fig. 2. Circuit diagram of the 32 Kbyte or 64 Kbyte RAM extension for MSX computers.

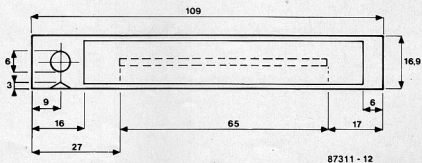

Fig. 3. Cutting and drilling details for the music cassette box.

```

4
10 * ..... 64k memory check
20 *
30 * This program first writes $H00 to each address from $H000 to
40 * $HFFF. It then checks each address, starting at $H000, and if
50 * the byte returned reads $H00, $HFF is written to that address.
60 * Next, each address is checked again, now starting at $HFFFF,
70 * and $H00 is written when the address reads $HFF.
80 * The current memory address is displayed in the top line of the
90 * screen. The program halts when a faulty address is found.
100 * The machine code $Y0$RAM can be halted by pressing
110 * keys [CTRL], [SHIFT], [GRAPH] and [CODE] simultaneously.
130 *
130 CLEAR $00,$H000: POKE $H170,1 ..... select primary slot number
140 POKE $MFB0,1: ..... enable stop by pressing ctrl-shift-graph-code
150 CLS: LOCATE 7,0: PRINT "Busy "
160 GOSUB 200
170 LOCATE 5,1
180 END
200 RESTORE 330
210 FOR I=0 TO $H1C
220 C=0
230 *
240 * FOR K=0 TO $HFF
250 * READ A$:B$=VAL("$(H)-A$)
260 * POKE$H000+I*16+K,B
280 * C=C+B
270 * NEXT K
280 * READ A$:IF C$=VAL("$(H)-A$)THEN 300
290 * PRINT "DATA ERROR IN LINE",330+I*10: END
300 NEXT I
310 DEFUSR0=$H000: A=USR(0)
320 RETURN
330 DATA 21,0,0,39,EB,21,0,BA, F9,DS,21,0,0,11,0,0,420
340 DATA CD,31,B1,3A,70,B1,CD,14,0,2C,20,F1,24,7C,FE,C0,786
350 DATA 20,EB,CD,31,B1,08,AB,FB, E6,3F,47,3A,70,B1,CD,FB,803
360 DATA CB,FB,80,F3,03,49,3E,0,77,B1,03,AB,FB,2C,20,E2,942
370 DATA 24,7C,FE,0,20,DC,21,0,0,3A,70,B1,CD,31,B1,CD,692
380 DATA C,0,FE,0,20,3A,11,FF,0,3A,70,B1,CD,14,0,2C,40C
390 DATA 20,E7,24,7C,2D,FD,AF,FE, C0,20,0E,CD,31,B1,0B,AB,973
400 DATA FS,E6,3F,47,3A,70,B1,CD,FB, CB,FB,80,F3,D3,AB,7E,90C
410 DATA FE,0,20,78,3E,FF,77,F1, D3,AB,FB,2C,20,DD,18,2,7FA
420 DATA 18,71,24,7C,FE,0,20,D3, 21,FF,FF,CD,21,B1,0B,AB,858
430 DATA FS,E6,3F,47,3A,70,B1,CD,FB, CB,FB,80,F3,D3,AB,7E,90C
440 DATA FE,FF,20,48,3E,0,77,F1, D3,AB,FB,2D,20,DD,25,7C,84C
450 DATA FE,8F,20,07,21,FF,8F,3A, 70,B1,CD,31,B1,0C,C,0,876
460 DATA FE,FF,20,2F,11,0,0,3A, 70,B1,CD,14,0,2D,7D,FE,641
470 DATA FF,20,E4,25,7C,FE,FF,20, DE,11,26,B1,21,7,0,6,6BD
480 DATA 9,14,CD,4D,0,23,12,5,20, F7,16,1A,3D,FC,AF,F1,35F
490 DATA D3,AB,FB,11,19,B1,21,7,0,6, D,1A,CD,4D,0,23,4E3
500 DATA 13,5,20,F7,16,0,E1,F9, C9,4D,45,4D,4F,52,59,20,5E3
510 DATA 4E,4F,54,20,4F,4B,AD,45, 4D,4F,52,59,20,4F,4B,0,43E
520 DATA 0,C5,D5,E5,FS,22,2F,B1, 21,2F,B1,11,5,0,3E,0,5CB
530 DATA 6,1,E,1,ED,67,FS,FE,A,38, 2,C6,7,C6,30,EB,64F
540 DATA CD,4D,0,EB,F1,1B,5,28, EB,ED,67,23,6,1,0,28,50C
550 DATA E3,F1,E1,D1,C1,C9,0,0,0,0, 0,0,0,0,0,0,0,0,510

```

8731-13

Fig. 4. This program can be used to test the RAM extension card.

Parts list

Resistors ($\pm 5\%$):

R1;R2=1K0

Capacitors:

C1;C2=100n

C3=100 μ ; 16 V; axial

Semiconductors:

T1=BS170 or BS170P (see text)

IC1;IC2=43256 or 62256 32K x 8 static RAM

(C-1 Electronics, Happy Memories)

IC3=74HCT32

Miscellaneous:

S1=miniature slide switch.

PCB Type 87311

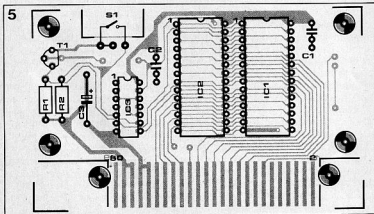

Fig. 5. Component mounting plan of the double-sided, through-plated, printed circuit board for building the RAM extension.

a fault is encountered, it displays MEMORY ERROR in the same location.

Finishing

The completed printed circuit board can be made into a compact and sturdy plug-in module by fitting it in a music cassette box — see the introductory photograph and the drawing of Fig. 3. After removing the lower panel of the box, the PCB is fitted by means of four screws and spacers. After spraying the box with paint, the extension module is ready for use.



Sony HitBit MSX micro upgraded with 64 Kbyte of random-access memory.

SHIELDING COMPUTERS WITH METAL-COATED GLASS

by Bill Pressdee, BSc, CEng, MIEE

Shielding for electromagnetic and radio-frequency interference (EMI/RFI) has two distinct functions. In the first instance, its purpose is to keep unwanted electromagnetic fields and unwanted transmission from interfering with sensitive electronic equipment. A second reason that has come about in recent years is keeping transmissions inside a given system.

For many years a shielded room, or Faraday cage, has been a prerequisite for exact setting up of electronic circuitry in conditions free from extraneous interference. Early shielded rooms, totally enclosed by an earthed metallic mesh frame were, however, often expensive to construct and claustrophobic.

The puncturing of the screen to introduce ventilation often created additional problems with the result that air flow was minimal. As a result of these indifferent working conditions much of the purpose of the Faraday cage was frequently confounded by personnel leaving the shielded door open.

In recent years, with an emergence in the diplomatic and military fields of extremely sophisticated eavesdropping

equipment, a second reason for shielding has come into prominence. As much emphasis is now placed on keeping transmissions in as keeping them out. This is equally true in the commercial field where radiation from computer circuitry can easily be detected by relatively simple equipment and valuable data siphoned off by those involved in commercial espionage.

In the United Kingdom and other countries where a Data Protection Act has been introduced it has, in any case, become a legal obligation for data to be adequately protected. A general tightening up of international standards relating to RF transmissions from electronic equipment in general, with stricter regulations governing this likely to be

come mandatory in Britain and most of Europe this year, has given a fillip to the shielded enclosure market.

In some cases where, for example, major computer installations are situated near airports or sites where there is the prospect of considerable interference from radar equipment, beacons, broadcast transmitters, mobile radios, and industrial or medical apparatus, there is a double problem. The shielding must ensure that unwanted transmissions do not corrupt data or hamper operation, and

at the same time must secure the integrity of the computer data from eavesdropping.

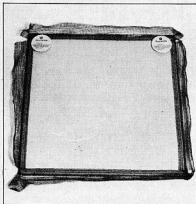

The laminated glass has a peripheral wire mesh strongly bonded to the conducting coating.

Problems of shielding

Effective shielding of computer rooms and sensitive electronic equipment can be achieved by enclosing them in a metallic cage of wire mesh. In the case of equipment, windows in the cage need to be provided to enable dials or displays to be read. In the case of computer rooms, particularly those manned on a round-the-clock basis, total enclosure is claustrophobic and oppressive in the absence of daylight.

Even where windows are provided, they have to be covered with wire mesh to ensure the shielding is complete and this may well add to the feeling of imprisonment.

An expensive alternative in the past where windows have had to be shielded against RFI was in the use of conductively coated glass. The preferred materials for coating were gold and indium tin oxide (ITO). The window size, however, has been restricted by the dimensions of the vacuum chambers available for deposition. In addition, in the case of ITO the cost of large pieces has been prohibitive because the deposition rate is slow, which means tying up expensive plant for long periods.

The problems of manufacturing large pieces of metallic coated glass at reasonable cost have been solved by Pilkington Glass, one of the world's foremost glass manufacturers. The process involves the use of very-large-scale magnetron sputtering equipment, capable of producing conductively coated glass in sizes up to 3.6 m x 2.5 m.

The plant operates on a continuous basis with vacuum locks on the main sputtering chamber enabling a very high manufacturing throughput. Many different materials can be deposited by this process, but for RFI shielding windows,

materials possessing high electrical conductivity combined with good optical properties in thin film form are chosen.

The result of this is a material that can be used in the manufacture of windows with an attractive appearance and little visual obscuration. While the shielding properties may not satisfy the most stringent specifications it is quite satisfactory for a wide range of applications such as windows for data sensitive areas like computer rooms, RFI shielding cabinet doors and video display unit (VDU) faceplates. The laminate protects the operator's upper body from bombardment by radiation, a suspected cause of headaches and other ills.

The coated glass is laminated to a second piece of glass to protect coating and a peripheral metallic mesh tape completes the shielding connection.

Types of coated glass

Several types of coated glass are available, depending on the thickness of conducting layer which will determine the degree of shielding from electromagnetic waves, and further types with improved performance are under development. The thickness of the layer will determine the surface resistance which is in the range 2 to 20 ohms/square (where ohms/square is the unit for measurement of surface resistance). The densest coating (2 ohms/square) naturally has the lowest optical transmission, which is of the order of 50%. Apart from the standard laminated sheet, an interesting case arises where a laminate is formed from two metallized glasses separated by a non-absorbing inter-layer less than 1 mm thick. Radiation that penetrates the first surface becomes trapped between the two surfaces, which act as mirrors, and only escapes after multiple reflections due to the high reflectivity.

Since the reflections are as likely to escape through either glass, roughly only half of the energy managing to penetrate the coating will be transmitted on into the shielded area. In practice, improvements in attenuation of 8 to 10 dB over the single coat laminate have been recorded.

From an architectural viewpoint an important additional consideration in selection of a glass type — provided the screening requirements are met — is the ratio of light to solar heat transmission. In the case of the 2 ohms/square coating, the relative percentages for reduction are 50/30, so by its employment there is considerable offspin.

In summer, the solar heat gain of the building through the windows is greatly reduced (to about one-third), while in the winter, the same applies to heat

losses from the building via the windows, providing for lower fuel bills.

Window construction

The conductive coatings may also be protected from abrasion by incorporation in a double-glazed unit. For internal applications the preferred construction is laminated, since it is less bulky and gives a much increased strength. The knitted wire mesh around the perimeter of the sheet is brought into good electrical contact with the coating by the pressure of the lamination process.

Double-glazed units are more suited to external or architectural use since this construction gives the additional benefit of lower heat loss. The conductive connection around the perimeter of the window unit may be of the wire mesh type or by depositing a robust metal coating. Where there is a need to provide RF shielding for an existing room with normal windows, secondary glazing is a possibility. The additional windows would be of laminated construction, mounted in a metal framework grounded to the rest of the structure, and constitute the least expensive option for a retro-fit.

A number of different coatings are under investigation. Where a coating durable enough to be used without protection is essential, one employing ITO can be offered, but cheaper coatings with similar properties are being developed. Also, a coating similar to the ones at present in use, but able to withstand the high temperatures involved in toughening and bending the glass for special applications, is under development.

Pilkington Glass Ltd, New Technology Business Unit, Cowley Hill Works, ST HELENS, WA10 3TT.

SELF-INDUCTANCE METER

Measuring self-inductance reliably is notoriously difficult and inductance meters are, therefore, few and far between and also quite expensive. The instrument described here offers reasonably accurate (within 1%) measuring of low-frequency inductors from $10 \mu\text{H}$ to 2H .

One of the reasons that the measurement of inductance is so tricky is that the value of inductance varies considerably with the conditions of measurement. The principal reason for the variation in inductance is the variation of permeability, which changes with the level of the test signal and the d.c. bias.

Principle of meter

When a non-constant current is passed through an inductance, an e.m.f., u , is induced whose magnitude depends on the rate of change of current, di , in a unit of time, dt , i.e.

$$u = L(di/dt).$$

If di/dt is kept constant ($=k$) by increasing or decreasing the current uniformly,

$$u = Lk$$

that is, the e.m.f. is directly proportional to the inductance (see Fig. 1).

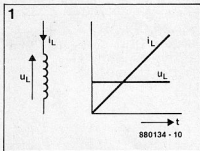

Fig. 1. A uniformly increasing or decreasing current through an inductor causes a constant voltage to be induced across the inductor.

In practice, however, it is impossible to create a uniformly increasing or decreasing current, but a good alternative is a current whose waveform is triangular (see Fig. 2). If such a current is passed through an inductance, the induced e.m.f. will have a rectangular waveform as shown in Fig. 2. If that e.m.f. is rectified, the resulting direct voltage is a measure of the inductance. Unfortunately, no inductance is pure: it

always has some internal resistance, R , in series with it. Thus,

$$u = u_L + u_R.$$

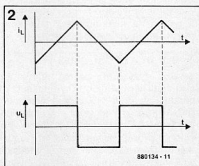

Fig. 2. A triangular current through an inductor causes a rectangular voltage across the inductor.

The three voltages are shown in Fig. 3. Rectification produces a direct voltage with a small sawtooth-shaped ripple, which is caused by u_R . The average value of the direct voltage (shown dashed in Fig. 3d), remains a true indication of the inductance, however. This shows that in this method of measurement the internal resistance of the inductor (unless it becomes large) does not affect the measurement.

Block schematic

The block diagram of the proposed meter is given in Fig. 4.

The function generator, consisting of a combination of an integrator and a Schmitt trigger, generates a triangular and a rectangular voltage.

The triangular voltage is converted into a triangular current superimposed on a direct current. The composite current, which is thus always greater than 0, is passed through the inductor on test, L_x . Range switching is effected by reducing the current by a factor 10 for each higher measuring range.

The a.c. component of the voltage across L_x is amplified and then applied to the first of three electronic switches, ES1 to ES3.

The electronic switches are controlled by the rectangular voltage from the function generator and provide half-wave synchronous rectification of the alternating voltage.

Since this type of rectification halves the average value of the input voltage, the preceding amplifier raises the magnitude of the a.c. component across L_x by a factor 2.

The rectified voltage is applied to a digital voltmeter, DVM, which displays the value of L_x in henrys.

Triangular current

If the DVM has a full-scale deflection, f.s.d., of, say, 200 mV, the input to it

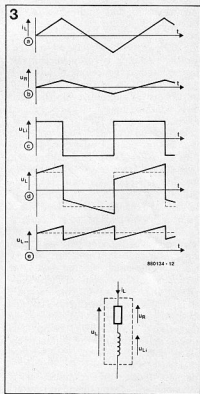

Fig. 3. In a practical inductor, its internal resistance causes a deviation from the rectangular shape of the induced e.m.f. The average value of this e.m.f. does not change, however.

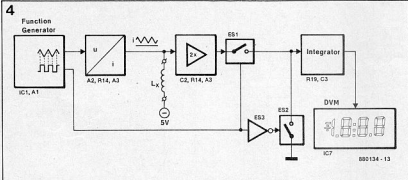

Fig. 4. The block diagram of the self-inductance meter.

when an inductance of 2 mH is being measured on the lowest range, must be 200 mV. In the following, it will be assumed that the maximum current, i_m , through the inductor is 20 mA (a reasonable value for inductors of 2 mH or smaller). Starting at one edge of the triangular current,

$$di/dt = u/L = 200 \times 10^{-3} / 2 \times 10^{-3} = 100.$$

Since the current increases linearly,

$$i_m/t_e = di/dt = 100$$

so that,

$$t_e = 20 \times 10^{-3} / 100 = 2 \times 10^{-4} = 200 \mu\text{s},$$

where t_e is the duration of the edge. The frequency of the triangular current is therefore

$$f = 1/2t_e = 1/2 \times 2 \times 10^{-4} = 2500 \text{ Hz.}$$

Circuit description

The function generator consists of integrator A1 and Schmitt trigger IC1. The frequency of the generated signal is, as calculated above, 2500 Hz.

The Schmitt trigger provides a square-wave voltage that is used to control electronic switches ES1 to ES3.

Resistor R3 provides a DC offset to ensure that the triangular voltage does not drop below 0 V. This is necessary for good control of the voltage-to-current converter.

Circuit IC1 is a Type 3130 opamp, which is one of the few devices whose output voltage can really be driven positive and negative. That output serves as reference voltage for the following integrator.

The output of A1 is a triangular voltage, which varies between 4.9 V and 2 V. The voltage-to-current converter around A2 and T1 transforms this voltage into a current that is passed through the inductor on test, L_x .

The value of the current, and thus the measuring range, is determined by resistors R5 to R8. When the 2 H range is selected, the current is $20/10^4 = 0.02 \text{ mA}$.

Resistors R9 to R11 in parallel with L_x provide some damping. This is necessary, because the inductor is also shunted by various parasitic capacitances (connecting wires, internal capacitance of the inductor, etc.) which results in an LC circuit. The high-impedance drive of this circuit (by a practically ideal current source) would certainly give rise to oscillations in the absence of some damping. The value of these resistors is chosen to ensure that they have a negligible effect on the measurement. Note that when the 2 H range is selected, R14 serves as damping element.

If an attempt is made to measure a small inductance with a high range selected, e.g., a coil of 1.5 mH in the 2 H range, it may be that the value of the damping resistor is too high, with the result that oscillations may occur. It is, therefore, advisable always to start in the lowest range and then switch to a higher range as required (shown by the absence of an overflow indication on the DVM). This

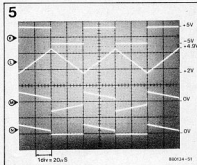

Fig. 5. The various waveforms in Fig. 4: L is the voltage applied to the voltage-to-current converter; a falling edge indicates an increasing current.

method also ensures the highest possible resolution.

The overflow indication is provided by comparator A4, which connects the input of the voltmeter to +5 V via ES4 when too low a range has been selected. Opamp A3 raises the magnitude of the measured alternating voltage by a factor 2. Note that C2 at its non-inverting input blocks any direct voltages. The offset of this opamp is compensated with the aid of P1.

The half-wave rectifier is formed by ES1 and ES2, while ES3 serves to invert the rectangular control pulses. During the positive part of the measured alternating voltage, ES1 is closed and ES2 is open; during the negative part, ES1 is open and ES2 is closed. The resulting steady voltage is smoothed with the aid of R19 and C3 and converted into a readable quantity by IC7.

The digital voltmeter consists of the well-known Type 7106 IC and a 3 1/2-digit LCD. The 7106 contains all that is necessary for converting a steady voltage into a digital quantity and displaying this on the LCD. The decimal points of the display are provided by XORs N1 to N3. Which decimal point is visible depends on the position of switch S2c. LEDs D8 and D9 indicate whether the display must be read in henrys or millihenrys.

The voltmeter is powered by two 9-volt PP3 batteries and two voltage regulators. Note that the 7805 and 7905 regulators provide better interference suppression than the smaller L types.

Construction

The meter, constructed on the PCB shown in Fig. 7, fits in a small, hand-held case.

All resistors and diodes are mounted upright, except R1, R3, and R24. Electrolytic capacitors should be PCB types. Sockets should be used for the ICs. The display is best mounted on some stacked terminal boards so that it is located just under the window in the enclosure.

Specification

| Measuring ranges | |
|---------------------------------|--|
| 0.2–2 mH (resolution 1 μ H) | |
| 2–20 mH (resolution 10 μ H) | |
| 20–200 mH (resolution 0.1 mH) | |
| 0.2–2 H (resolution 1 mH) | |

Internal resistance of coil for a measuring error smaller than 1% of full-scale deflection

| Range | |
|------------|------|
| 0.2–2 mH: | 60R |
| 2–20 mH: | 600R |
| 20–200 mH: | 6 k |
| 0.2–2 H: | 60 k |

Measuring frequency 2500 Hz

Accuracy Better than 2% of f.s.d.

Current drawn About 20 mA

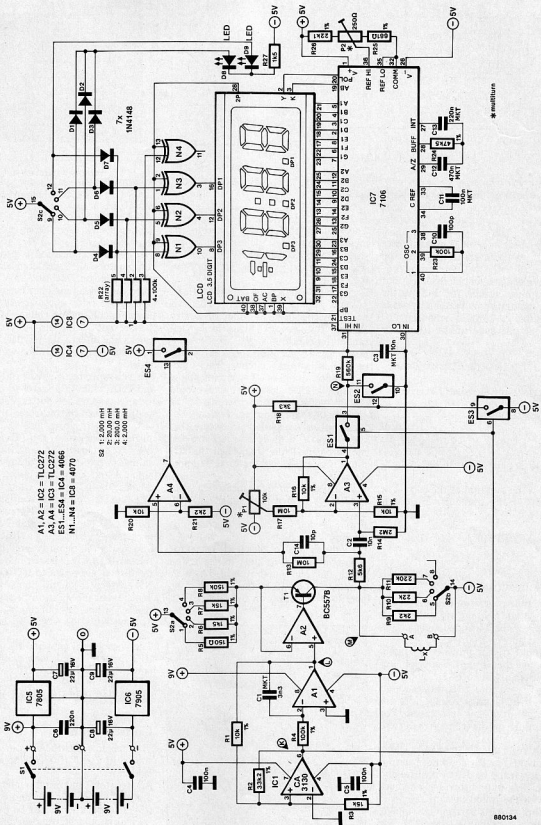

880134

Fig. 6. The circuit diagram of the self-inductance meter.

Parts list

Resistors:

R1;R15;R16 = 10 k 1%
 R2 = 33k2 1%
 R3;R7 = 15 k 1%
 R4 = 100 k 1%
 R5 = 150R 1%
 R6 = 1k5 1%
 R8 = 150 k 1%
 R9;R21 = 2k2
 R10 = 22 k
 R11 = 220 k
 R12 = 5k6
 R13;R17 = 10 M
 R14 = 2M2
 R18 = 3k3
 R19 = 560 k
 R20 = 10 k
 R22 = array of 4 x 100 k or four discrete 100 k

resistors

R23 = 100 k
 R24 = 47k5 1%
 R25 = 681R 1%
 R26 = 22k1 1%
 R27 = 1k5
 P1 = 10 k multitrurn preset (e.g. Bourns Type 3266)
 P2 = 250R multitrurn preset (e.g. Bourns Type 3266)

Capacitors:

C1 = 3n3*
 C2;C3 = 10 n*
 C4;C5 = 100 n
 C6 = 220 n
 C7;C8;C9 = 22 μ ; 16 V (radial)
 C10 = 100 p
 C11 = 100 n*
 C12 = 470 n*
 C13 = 220 n*
 C14 = 10 p

* metallized polyester or metallized polycarbonate

Semiconductors:

D1 to D7 = 1N4148
 D8;D9 = LED 3 mm red
 T1 = BC557B
 IC1 = CA3130
 IC2;IC3 = TLC272
 IC4 = 4066
 IC5 = 7805
 IC6 = 7905
 IC7 = 7106
 IC8 = 4070

Miscellaneous:

LCD = 3 1/2-digit liquid crystal display
 S1 = double-pole on-off switch
 S2 = rotary switch, 4-position, 3-pole
 2 batteries, PP3 (9 V)
 2 spring action terminals
 enclosure 155 x 92 x 33 mm (e.g. QW A9409111)
 PCB Type 880134

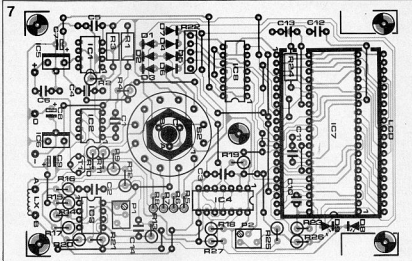

Fig. 7. The PCB for the self-inductance meter.

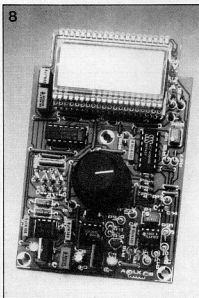

Fig. 8. Prototype of the self-inductance meter before it is fitted in the enclosure.

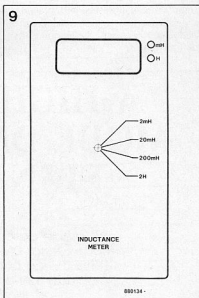

Fig. 9. Design of a possible front panel for the self-inductance meter.

R22 is an array of four 100 k resistors; this may be replaced by four discrete 100 k resistors that are mounted upright with their upper terminals interconnected.

The LEDs are mounted at such a height that they are seated just under the front panel once the PCB has been installed in the case.

The rotary switch is soldered direct to the PCB to make the best possible use of the available space and also to prevent noise and interference from connecting wires.

The centre pin of IC5 and IC6 should be bent forward so that the pins form a triangle (just as with a standard transis-

tor). The ICs are mounted on the PCB with their case just clear of the board: this means that the wider part of the pins also goes into the relevant hole, which allows for this. Where a very flat enclosure is used (possible), it may be necessary to carefully cut off the metal tops of IC5 and IC6.

To secure the PCB, three holes must be drilled in the case: the non-populated board may be used as a template. Switch S1 is best mounted at one of the sides of the case, while the two batteries may be located at the underside of the enclosure (after the small mouldings have been removed).

Note that the mouldings on the lid

should also be removed before the display is mounted.

The spring action terminals for connecting the inductor on test should be fitted at one of the sides of the enclosure as close as possible to the relevant pins on the PCB.

Calibration

An inductor of between 1 and 1.8 mH, whose value is accurately known, is required for the calibration. A cross-over filter coil with an accuracy of better than 3% may suffice, but some retailers can provide an air-cored inductor of 1.5 mH with an accuracy better than 1%.

It is also possible to determine the inductance of an air coil of about 1–1.5 mH accurately as follows. Connect it in parallel with a capacitor of 47 nF or 100 nF (accuracy 1% or 2%) and connect this circuit via a series resistor of about 3.3 k to a frequency generator. The resonance frequency of the circuit is then determined with the aid of an oscilloscope and a frequency meter. The self-inductance of the air coil is then calculated from

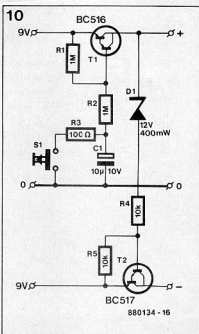

Fig. 10. This small circuit may be added to ensure automatic switch-off of the batteries.

$$L = 1/(2\pi f)^2 C [H].$$

Short-circuit the measuring terminals and select the 20 mH range.

Adjust P1 till the display read 0.000. Connect the reference coil to the measuring terminals and select the 2 mH range. Adjust P2 till the display reads the exact value of the reference coil.

Since the accuracy and precision of the other ranges are determined by the tolerance of resistors R5 to R8, this completes the calibration.

Automatic switch-off

The meter draws about ± 20 mA. A pair of batteries will have a fairly long life, as long as they are always switched off when the meter is not in use.

Forgetful users may find the circuit in Fig. 10 ideal: this automatically switches the batteries off after about half a minute. The meter is switched on again by pressing the reset button. This circuit may be connected behind S1 or simply replace it altogether. The meter is then always switched on by pressing the reset button.

A HIGH-SPEED DEPLETION-MODE DMOS FET FOR SMALL-SIGNAL APPLICATIONS

by Alan Pritchard

This article describes a new ultrahigh-speed n-channel depletion-mode lateral DMOS transistor geared for small-signal applications.

This device boasts high-performance characteristics, which include turn-on speeds of less than 1 ns; low reverse-transfer capacitance of less than 2.5 pF; high-frequency transconductance greater than 10 ms; a wide dynamic range; and low distortion.

Fig. 1a and 1b show idealized cross-sections of the 'normally-on' depletion mode and 'normally-off' enhancement-mode devices. Because these device structures are similar, the device characteristics are also similar. In fact, the depletion-mode device may be thought of as an enhancement-mode device with a negative threshold voltage.

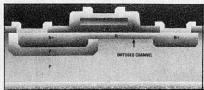

Fig. 1a. Depletion-mode device cross-section.

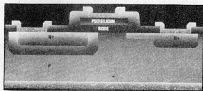

Fig. 1b. Enhancement-mode device cross-section.

Unlike enhancement-mode devices, whose drain current falls to zero when the gate-to-source voltage equals zero, the new depletion-mode FET has appreciable current at zero gate signal. In fact, the drain-to-source resistance is

typically 100 Ω at zero voltage. As shown on Fig. 2, the on-resistance $R_{DS(on)}$ versus analogue signal range is an almost flat response. This characteristic, coupled with the low-capacitance values of the new device, makes it particularly suitable as an analogue switch for audio and video switching applications.

The depletion-mode 'normally-on' characteristic makes the FET useful for single-device current regulators. This type of circuit, usually associated with junction FETs, is shown in Fig. 3. The value for R_S can be calculated from:

$$R_S = \frac{V_{GS(off)} [1 - (I_D/I_{DSS})^{1/2}]}{I_D}$$

where I_D is the required value of regulated current.

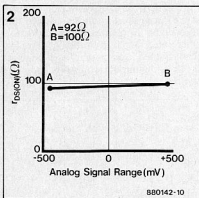

Fig. 2. On-resistance versus analogue signal range for the SD2100 depletion-mode DMOS FET.

The major advantage of depletion-mode MOSFETs in current-source circuits is

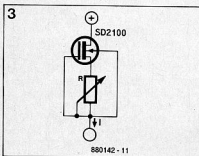

Fig. 3. Single-device current regulator.

their low drain capacitance, which makes them suitable for biasing applications in low-input leakage, medium-speed (>50 V/ μ s) circuits. Fig. 4 shows a low-input-leakage current differential front-end employing a dual low-leakage junction FET.

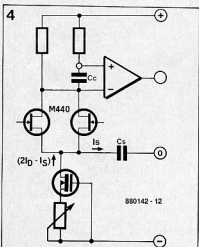

Fig. 4. Low bias-current differential front-end using an M440 JFET. Note C_c reduces the maximum current swing available to charge C_c , thus reducing the slew rate.

In general, each side of the JFET will be biased at $I_D = 500 \mu A$. Thus, the current available for charging compensation and stray capacitances is limited to $2I_D$ or, in this case, 1.0 mA. The JFET's matching characteristics are production-tested and guaranteed on the data sheet.

C_s represents the output capacitance of the input stage 'tail' current source. This capacitance is important in non-inverting amplifiers, because the input stage undergoes considerable signal excursions in this connection, and the charging currents in C_s may be large. If standard current sources are used, this tail capacitance may be responsible for marked slew-rate degradation in non-inverting applications (as opposed to inverting applications, where the charging currents in C_s are very small).

The slew-rate reduction may be shown as:

$$\frac{1}{1 + (C_s/C_c)}$$

As long as C_s is small compared to C_c (the compensation capacitor), little change in slew rate occurs. Using the DMOS FET, C_s is about 2 pF. This approach yields a significant slew-rate improvement.

Where I_{DSS} currents greater than 1 to 5 mA are required, the device may be biased into the enhancement mode to produce up to 20 mA for a V_{GS} of +2.5 V maximum, with low output capacitance remaining a major feature. Fig. 5 shows a suitable enhancement-mode current source.

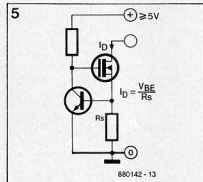

Fig. 5. Enhancement-mode current source.

A 'normally-on' analogue switch can be constructed for applications where default condition is required at supply

failure, such as for automatic ranging of test equipment or for guaranteeing correct initialisation of logic circuits at start-up.

The low negative threshold voltage of the device gives simple drive requirements and allows low voltage operation. Fig. 6 shows the typical bias conditions for a depletion-mode DMOS analogue switch.

To turn the device off, a negative voltage is required on the gate. However, the on-resistance can be reduced if the device is further enhanced with a positive gate potential, allowing it to be used in the enhancement-mode region as well as in the depletion-mode region. This effect is shown in Fig. 7.

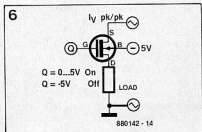

Fig. 6. 'Normally-on' analogue switch.

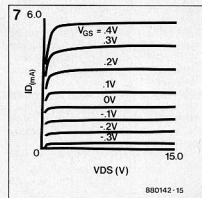

Fig. 7. Current versus drain-to-source voltage for the Siliconix SD2100 DMOS FET.

The high-frequency gain of the device, along with its low capacitance values, produces a high 'figure of merit'. This is an important factor in VHF and UHF amplification, and defines the gain-bandwidth product (GBW) of the device, which may be expressed as:

$$GBW = \frac{g_m}{2\pi(C_{in} + C_{out})} \quad (3)$$

For a common-source configured amplifier, this becomes:

$$GBW = \frac{gfs}{2\pi(C_{iss} + C_{rss})} \quad (4)$$

where:

- C_{iss} = short-circuit input (Miller) capacitance = $C_{gs} + C_{dg}(1 - AV)$;
- C_{gs} = gate-source capacitance;
- C_{dg} = feedback capacitance;
- C_{rss} = short circuit reverse transfer capacitance = C_{dg} .

It is evident that the gain-bandwidth product is largely dependent on the device gain and the feedback capacitance. If typical values for the new DMOS FET are substituted in Eq. 4, including the low feedback capacitance of 2.5 pF, the gain-bandwidth product is found to be greater than 400 MHz, a useful value in VHF and UHF operation.

The high figure of merit is also reflected in the nanosecond turn-on times which are important in applications such as sync-pulse generation for high-definition video systems, signal routing for high-speed digital video recording where data rates of greater than 100 Mbit/s are possible, and outside broadcasting systems where signal switching is required during blanking periods. Fig. 8 shows a high-performance video d.c. restorer. In these applications, the low distortion characteristics are important.

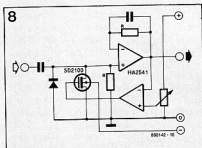

Fig. 8. High-performance video d.c. restorer using the SD2100.

The new device is also useful in applications that require both low charge injection and high switching speeds. For

example, a 'de-glitch' circuit for the output of a high-speed digital-to-analogue (D/A) converter, such as those found in video waveform generators, can take advantage of the device's high speed, low capacitance, and low distortion.

Glitches at the D/A converter output, as shown in Fig. 9, are generated during the switching transition times, when time skew allows incoming and previous data to overlap. The worst-case occurrence is at MSB (most significant bit) switching (e.g. from 0111111 to 10000000).

samples the output some time after it has settled. As D/A converter performance improves, settling times approaching 10 ns have become possible; therefore, fast-switching, low-capacitance sample-and-hold circuits, such as the one shown in Fig. 10, are required.

Alan Pritchard is with Siliconix.

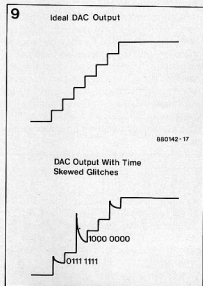

Fig. 9. Effect of time-skew glitches at D/A converter output.

A de-glitch circuit effectively forms a sample-and hold function which

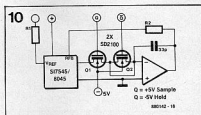

Fig. 10. 'De-glitched' D/A converter using two SD2100 devices. Note: Charge injection is reduced by complementary drive to Q1 and to Q2, which acts as a 'dummy' capacitor.

MICROPHONE PREAMPLIFIER WITH ACTIVE FILTER

by S.G. Dimitriou

When a microphone is used a good distance away from an amplifier, its relatively small output signal is inevitably affected by noise and attenuation caused by the cable.

The simple, yet versatile, preamplifier/line driver described here can be used with a variety of microphones, has a user-defined frequency response, and prevents signal degradation because its ability to load long cables enables it to be installed near the signal source.

Many types of modern audio equipment have a built-in microphone, or allow an external microphone to be attached semi-permanently. This is the general case with portable tape or cassette recorders, video and movie cameras. In spite of the apparent benefits of having a built-in microphone, this will almost always pick up mechanical noise from the equipment it belongs to. Also, it is of little or no use when sounds from remote sources are to be recorded, as the level of ambient noise is bound to exceed that of the wanted sound.

Obviously, reasonable signal-to-noise ratios and, therefore, good-quality recordings, can only be achieved when the microphone — or microphones — is installed relatively close to the source of the sound, but this arrangement necessitates the use of a long coaxial cable between microphone and associated equipment. With cable capacitance typically of the order of 200 pF/m, up to 100 m of coaxial cable with $Z=600 \Omega$ may be used without running into considerable attenuation of the upper part of the audio spectrum. In this case, the cut-off frequency, f_c , becomes:

$$f_c = 1/(2\pi RC) \text{ [Hz]}$$

$$f_c = 1/(2\pi \times 600 \times 20 \times 10^9) \text{ [Hz]}$$

$$f_c = 13.263 \text{ kHz}$$

In practice, however, the microphone impedance often rises with frequency, so that the cable must be kept shorter to prevent bandwidth reduction. In any case, it is not a very good idea to have the small microphone signal travel through any appreciable length of cable, as this will cause degradation of the signal-to-noise ratio.

A better method is to amplify the signal locally, i.e., as close as possible to the

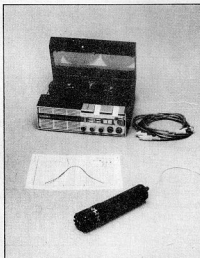

microphone, and drive the coaxial line by means of an amplifier with low output impedance. In this way, the wanted signal on the line is too strong to be affected by noise or capacitive loading. The signal amplitude can be reduced fairly easily at the receiver end with the aid of a two-resistor voltage divider (Fig. 1), in which

$$R_2 \approx 0.9A R_1$$

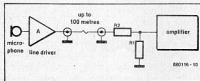

Fig. 1. A line driver with attenuator to overcome microphone signal degradation in a long coaxial cable.

where A is the amplification of the line driver, and $R_1=100 \Omega$ (typical value).

Bandwidth and filtering

The line driver is readily modified to operate as an active filter that can help to improve the signal-to-noise ratio of the sound picked up by the microphone. This is particularly useful in applications involving the recording of speech signals. From acoustic engineering it is known that the frequency spectrum of speech has relatively large redundant parts. The dynamic and spectrum-related characteristics of speech have been widely studied, but a further discussion of this interesting field is, unfortunately, beyond the scope of this article. Here, it is sufficient to say that a simple Wien-type bandpass filter can aid in shaping the spectrum such that speech becomes more intelligible due to the elimination of redundant signals and a good deal of ambient noise. In this way, the signal-to-noise ratio of the sound picked up by the microphone is significantly improved.

The response of the standard, passive, Wien filter is fairly smooth (Fig. 2), making it suitable for use with music signals without unduly affecting the original sound.

Practical circuit

The preamplifier/active filter proposed here is mainly intended for use with low-impedance dynamic or electret microphones. Electret microphones offer a wide frequency response, supply a relatively large output signal, and are of small size. They do have the disadvantage of requiring a biasing voltage, but this is no problem here as a supply is re-

quired anyway for the line driver.

With reference to the circuit diagram of Fig. 3, the line driver is built around low-noise operational amplifier IC₁, which is configured to work as an inverting active Wien filter. With the values shown for R₁, R₂, C₁ and C₂, the centre frequency of the filter will be 3.3 kHz nominally:

$$f_0 = 159,155 / (R_1 C_1)$$

with R₁ in kilo-ohms and C₁ in nanofarads. Related to the acoustic behaviour of the human ear, and with reference to the audible threshold curves set up by Fletcher and Munson⁽¹⁾, 3.3 kHz corresponds to the point of maximum sensitivity. The filter suppresses both low frequencies (whose reverberant nature tends to impair intelligibility of speech) and frequencies above 10 kHz, which can be considered as noise in the context of the spectral redundancy of speech.

The voltage amplification, A, of the line driver is about 10 at the passband centre frequency, and the value of the gain- and frequency-determining components is calculated from

$$R_1 = 2A R_2 \quad \text{and} \quad C_2 = 2A C_1$$

Components C₃ and R₃ ensure DC blocking at the output and phase stabilization respectively. The latter function is required to isolate the distributed capacitance of the coaxial cable from the feedback network of IC₁, thus preventing parasitic high-frequency oscillation. Evidently, the value of R₃ should be kept as low as possible, because otherwise the benefit of the low output impedance of IC₁ (as seen from the line) is lost. The resistor may be omitted if the LF356 is replaced with a (less expensive) 741, but this, unfortunately, increases the output noise level.

Potential divider R₁-R₂ biases the non-inverting input of IC₁ at half the supply voltage. LED D₁ is the power indicator. It is connected in series with the rest of the circuit to minimize the total current drain from the 9 V (PP3) battery. In this way, the preamplifier draws only 4.5 mA, which is still sufficient to light a LED with good efficiency. Owing to the drop across D₁, the preamplifier works from a supply voltage of 7 to 7.5 V.

Microphone and supply options

The basic circuit diagram of Fig. 3 shows a 3-terminal electret microphone. This will typically have an output impedance of 500 Ω or less, which is low with respect to the value of R₂, so that the microphone has very little effect on the centre frequency of the active filter. Where a 2-terminal electret microphone

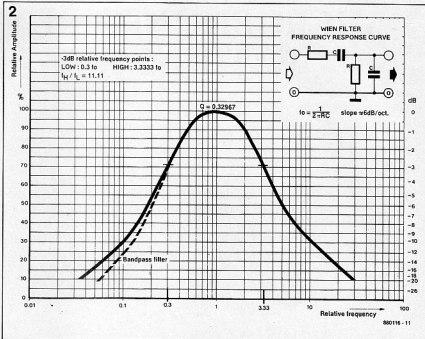

Fig. 2. Basic design and response of the Wien-type passive bandpass filter.

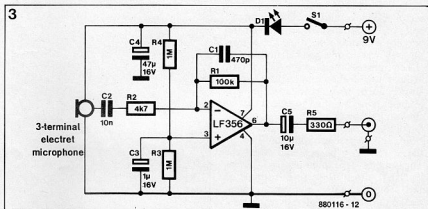

Fig. 3. Circuit diagram of the microphone preamplifier/line driver.

Table 1

Active filter response for A = 5

| A | f ₀ | f _H | RC | BW | R ₁ | C ₁ | R ₂ | C ₂ | Remarks/applications |
|------|----------------|----------------|---------------------|-------|----------------|----------------|----------------|----------------|-----------------------------------------|
| [Hz] | [Hz] | [Hz] | [μs] | [Hz] | | | | | |
| 217 | 723 | 2410 | 220 | 2193 | 220K | 1n0 | 22K | 10n | narrow bandwidth, mellow sound |
| 300 | 1000 | 3333 | 150 | 3033 | 150K | 1n0 | 15K | 10n | narrow bandwidth, pronounced consonants |
| 450 | 1500 | 5000 | 110 | 4550 | 330K | 330p | 33K | 3n3 | public-address response |
| 680 | 2200 | 7333 | 72 | 6673 | 220K | 330p | 22K | 3n3 | narrow-band music reproduction |
| 990 | 3300 | 11000 | 47 | 10010 | 47K | 1n0 | 4K7 | 10n | for low-level hearing |
| 1480 | 4800 | 16000 | 33 | 14850 | 100K | 330p | 10K | 3n3 | high harmonics content |
| 208 | -- | 6100 | $\frac{816}{28}$ | 5900 | 68K | 390p | 12K | 68n | speech intelligibility spectrum |
| 20 | -- | 20000 | $\frac{8180}{7.95}$ | 19980 | 68K | 120p | 12K | 680n | nominal Hi-Fi bandwidth |

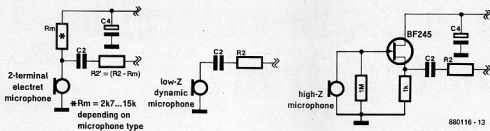

Fig. 4. Methods of connecting three types of microphone to the preamplifier input. Fig. 4a: 2-terminal electret microphone; Fig. 4b: low-impedance dynamic microphone; Fig. 4c: high-impedance dynamic or crystal microphone.

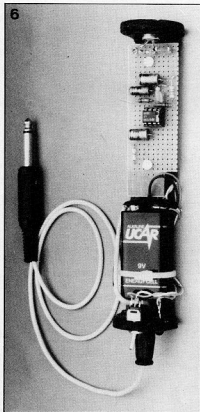

Fig. 6. The electret element and preamplifier mounted on a small piece of veroboard that can be inserted into a tube, together with the battery.

is used, the value of R_2 must be reduced to compensate the higher output impedance — see Fig. 4a. Figures 4b and 4c show the input circuits required for a low-impedance dynamic microphone and a high-impedance (or crystal-) microphone respectively.

As to the power supply for the preamplifier, this can be fed either by a battery as already discussed, or by an existing 12 to 15 V supply available in the power amplifier. In this case, only an ad-

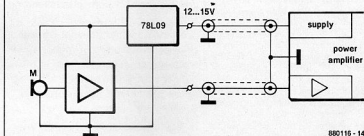

Fig. 5. The preamplifier can be powered via a separate wire in the cable to the power amplifier.

ditional 9 V regulator is required near to, or as part of, the microphone preamplifier. The +12 to 15 V input voltage for this regulator is conveniently carried via the centre core of one of the wires in the stereo shielded cable to the power amplifier.

Shaping the filter response

The centre frequency of the active filter set up around IC₁ can be selected for the application in question by redimensioning C_1 , C_2 , R_1 and R_2 on the basis of the previously shown formulas. Some commonly used frequencies and time constants are 723 Hz (220 μ s), 1 kHz (150 μ s), 1.5 kHz (110 μ s), 2.2 kHz (72 μ s), 3.3 kHz (47 μ s) and 4.8 kHz (33 μ s).

The filter can also be given a different frequency response. For example, it could be made wider to pass the spectrum from 200 Hz to 6100 Hz, which has been recommended for optimum intelligibility of speech⁽²⁾. For narrow-band music reproduction, a centre frequency of 1.5 kHz should be a good compromise between minimum required bandwidth and frequency response of loudspeakers typically used in public-

address systems. Table 1 gives some useful design values and possible applications (voltage gain $A = 5$).

Construction

Construction of the preamplifier should be relatively easy on a small piece of Veroboard. This can be fitted in a cylindrical enclosure, together with the power switch, LED, battery and the microphone element — Fig. 6 shows a suggested arrangement. It is recommended to cover the battery and the board in small plastic bags to prevent any likelihood of a short-circuit. The excess material is wrapped around these elements, which are then carefully pushed into the tube. In this way, all parts are held securely in place without the need for mounting hardware.

References:

- (1) *Audio handbook*, pp. 2-45. National Semiconductor Publication.
- (2) *The Design of Speech Communication Systems*. Proceedings of the IRE, vol. 35, pp. 880-890, ed. 1947.

temperature-controlled soldering iron

Since the days when soldering irons were heated up on gas rings, the design of this virtually indispensable piece of equipment has come a long way. There is now a wide variety of different types of iron available, allowing power rating as well as size, shape and composition of the bit to be selected to suit a particular application. Despite this plethora of different irons, it is nonetheless possible to discern two basic categories, namely continuous heat and temperature-controlled soldering irons. With the former type, the heating element is connected continuously to the supply, with the result that the iron tends to run very hot when not being used.

This means that the first joint made after the iron has been left standing may be too hot, thereby incurring the risk of a bad joint or of damage to delicate components. If one attempts to combat this problem by using a lower power iron, there is the danger that, under heavy load conditions, it may be unable to supply sufficient heat and will make a dry joint. A further disadvantage of continuous heat irons is that their tendency to overheat shortens the effective life of the bit and causes a reduction in the heating capability of the iron.

Temperature-controlled irons on the other hand suffer from none of these drawbacks. The only reason that they have not completely replaced continuous heat types is the fact that they cost much more. However, with the current trend towards ever smaller and more sensitive components, the decision to purchase a temperature-controlled iron may well prove a worthwhile long-term investment (particularly if one considers saving the cost which results from building the control unit oneself).

Thermostatically controlled soldering irons must not only be able to maintain a constant bit temperature (to within a few degrees Centigrade), it must also be possible to vary the soldering temperature to suit different requirements. Designing a suitable control unit, which both meets the above conditions and yet is a reasonable financial proposition for the amateur constructor, is no easy matter. However, the circuit described in this article adequately fulfils all the

Electronic temperature-controlled soldering irons offer a number of advantages over continuous heat types: delicate components are protected against thermal damage; they permit the use of higher wattages, thereby eliminating the danger of dry joints when working under heavy load conditions; and finally they increase the life of both heating element and bit. The following circuit is for a thermostatic control unit, which is both easy to build and uses standard components. Suitable soldering irons containing a built-in heat sensor are readily available from a number of different manufacturers.

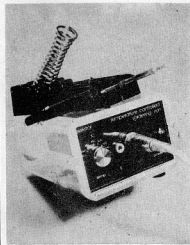

desired design criteria at a price which is roughly halfway between the cost of a conventional continuous heat iron and that of a commercially available temperature-controlled model. The control unit is designed for use with a readily available soldering iron incorporating a heat sensor in the shaft adjacent to the tip of the bit.

Electronic control unit

The principle of the electronic thermostatic control unit is illustrated in the block diagram shown in figure 1.

A sensor mounted in the element as near as possible to the bit tip provides a voltage which is proportional to the bit temperature. This voltage is then compared with a (variable) reference voltage on the other input of a comparator, the output of which is used to control a switch which regulates the flow of current to the heating element in the iron. Thus, when the sensor voltage is lower than the reference value, the switch is closed, current flows to the heating element and the bit temperature rises; once the desired temperature is reached, the comparator output changes state, opening the switch and thereby cutting off the flow of current to the heating element. The bit temperature then falls until the threshold voltage of the comparator is again reached and the control switch is opened. In this way the temperature of the bit can be maintained within a certain fixed range. The amount of hysteresis between a change in temperature and the corresponding change in sensor voltage is determined by the thermal inertia of the sensor itself and the thermal conductivity of the bit (which in turn is determined by the size and composition of the bit).

The deviation from the nominal bit temperature as a result of the hysteresis of the control system is illustrated in figure 2. As can be seen, the bit temperature oscillates about a preset nominal value; the steepness of the rising edge of the triangular waveform is largely determined by the output power of the heating element, and that of the falling edge by the rate at which heat is lost to the atmosphere, solder, p. c. b.

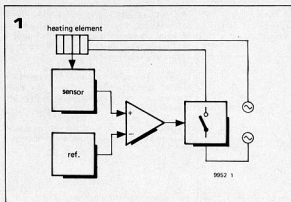

etc. In practice however, the bit temperature only deviates very slightly from the desired nominal value, so that it is in fact possible to speak of an average working temperature of the iron.

As far as the choice of heat sensor is concerned, various possibilities come into consideration. The firm Weller, for example, manufacture a heat sensor which utilises an unusual property of magnetic materials. Above a certain temperature, known as its Curie point, a ferromagnetic material loses the property of magnetism. The bit of a Weller iron contains a slug of magnetic material, which, when the iron is cold, attracts a magnet. This in turn closes a switch and applies power to the heating element. When the temperature of the bit reaches the Curie point, the slug ceases to attract the magnet, causing the switch to be opened. The only disadvantage of this system is that a disabit bit containing a ferromagnetic slug with the appropriate Curie point is needed to change the soldering temperatures.

Other manufacturers employ heat sensors consisting of a thermocouple or of an NTC- or PTC thermistor, usually as part of a bridge circuit. One branch of the bridge is formed by a variable resistor with which the bridge is balanced. In practice this means that the temperature range of the bit is determined by the range of the resistor.

Of the above-mentioned types of sensor, the thermocouple represents the best choice. The reasons for this are clear when one compares it with temperature-dependent resistors. Firstly, the dimensions of the thermocouple are smaller than those of an NTC or PTC thermistor, which means that it is easier to mount close to the tip of the bit, and also that, because of its reduced mass, it responds more quickly to changes in temperature. The response of a thermocouple (voltage as a function of temperature) is, as figure 3 clearly shows, linear over a wide range of temperatures. NTC- and PTC thermistors, on the other hand, exhibit a far less linear characteristic. Furthermore, a thermocouple has no quiescent current flow to speak of, and hence will not generate any heat itself. The final point in its favour is the lower cost of thermocouples, a not insignificant factor

when temperatures of the order of 400°C are involved.

Figure 2. The response of a typical thermostatic control unit. The temperature first climbs to the desired (preset) value. However, once it reaches this value the temperature continues to rise, due to the inherent hysteresis of the system, before the interruption of current to the heating element begins to take effect. Similarly, when the temperature has fallen to the nominal value, it will continue to drop slightly before the renewed flow of current to the heating element can begin to push the temperature back up. Thus the actual bit temperature of the iron tends to oscillate about the nominal 'controlled' temperature. However, in practice these variations in temperature are sufficiently small not to significantly affect the performance of the iron, which remains at a more or less constant 'average' temperature.

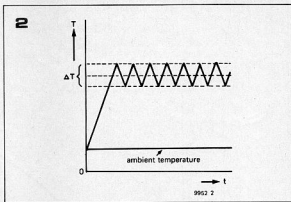

The Elektor control unit

In view of the above-mentioned points an iron which was both readily available and which incorporates a thermocouple as heat sensor was taken as the starting point of the Elektor control unit. Several manufacturers in fact distribute suitable soldering irons without the accompanying control unit. For example, the firm Antex produce a 30 W soldering iron (the CTC) which includes a thermocouple, as well as a 50 W model (XTC) which should be available shortly. Ersa are another company who have a suitable 50 W iron (TE 50).

In order to ensure the complete reliability of the Elektor control unit, it was in fact sent to Antex for assessment. Their verdict was summarised as follows: 'The performance of the sample tested should be perfectly adequate for the Home Constructor'. Furthermore, the control unit can also be used with soldering irons from most of the other manufacturers, even if they contain NTC- or PTC thermistor sensors, although in that case certain changes will have to be made to the circuit.

Without entering into the theoretical details, it should be noted that different combinations of materials can be used to construct thermocouples, and that each will deliver a different output voltage for a given temperature. For their CTC and XTC models, Antex use a K-type thermocouple, which is composed of nickel-chrome and nickel-aluminium. The response shown in figure 3 was obtained using this type of thermocouple.

Circuit diagram

The complete circuit diagram of the thermostatic control unit is shown in figure 4. Despite the small number of components used, the operation of the circuit is somewhat involved, and for this reason figure 5, which contains an overview of the waveforms found at the test points shown, is included to facilitate explanation.

The first problem which arises is the

3

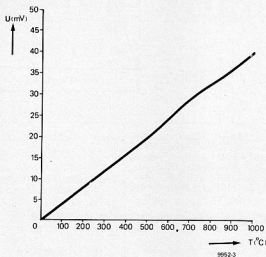
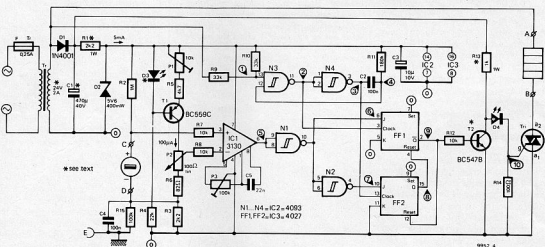

Figure 3. The temperature-voltage characteristic of a nickel-chrome/nickel-aluminium thermocouple (the type used in e.g. Antex soldering irons). As is apparent, the response is virtually linear over the temperature range of this particular application.

Figure 4. The complete circuit diagram of the Elektor thermostatic control unit. The modifications needed for the 40 V version are listed in table 1.

Figure 5. Pulse diagram of the various signals obtained at the test points shown in figure 4.

4



choice of switching element to regulate the flow of current to the iron. The use of a relay involves several drawbacks (contact burning, contact bounce etc.) which can be avoided by employing an electronic switch such as a triac. An additional advantage of a triac is that the switching point can be controlled with a high degree of accuracy, i.e. in order to reduce the switch-on surge current and r.f. interference to a minimum, the triac can be triggered at the zero-crossing point of the AC waveform. This is in fact the arrangement adopted in the circuit described here.

R4, D3, T1 and the emitter resistors of T1 form an adjustable constant current source. D3 is a LED used to set the DC base bias voltage of T1, but since it draws very little current it will hardly light up at all. The advantage of this somewhat unusual approach is that the LED possesses the same temperature coefficient as T1, hence the stability of the current source is unaffected by variations in temperature. This is only true, however, if the ambient temperature of the circuit does not rise too far above normal room temperature, since in that case the temperature coefficient

of the LED will cease to match that of T1. Thus, if when the circuit and transformer have been mounted in a case, the temperature should rise by more than 30°C, D3 should be replaced by an 8k2 resistor. This step will obviously be necessary if the soldering stand is to be mounted on top of the control unit case. The current through P2 and R6 can be varied by means of P1. P2 determines the amplitude of the reference voltage at the inverting input of IC1. The thermocouple is connected across the non-inverting input of IC1 and the junction of R3/R6. Thus the voltage

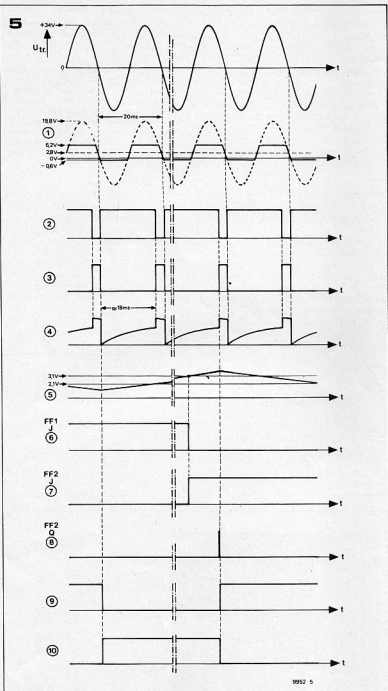

difference at the inputs of the comparator equals the difference between, on the one hand, the voltage dropped across R6 plus the resistance of P2, and on the other hand, the voltage developed by the thermocouple. That is to say, it virtually equals the thermocouple voltage.

If the soldering iron is cold, the thermocouple voltage is very small, so that the output of IC1 is low. When the temperature of the iron rises, the thermocouple voltage, and hence the voltage difference at the comparator inputs, also rises, until the output of the

comparator swings high.

IC1 is followed by a Schmitt trigger, the output of which goes low when the input exceeds approx. 3.2 V, and high when it falls below roughly 2.1 V. This arrangement could be used directly to control the triac were it not that we have to first ensure that the load is switched at the zero-crossing points of the transformer voltage. To achieve this, one or two extra provisions are required. The transformer voltage (U_{tr} in figure 5) is connected to the input of N3 via a potential divider, R9 and R10, one end of which is connected to the stabilised

5.6 V supply rail. This means that the voltage at point 1 (the input of N3) exactly tracks the transformer voltage, whilst remaining 2.8 V 'up' on the latter (see figure 5). The portion of waveform above 6.2 V and below -0.6 V is shown as a dotted line, since CMOS Schmitt triggers contain clamping diodes which protect the inputs from voltages which exceed these limits.

The advantage of the 2.8 V positive offset is apparent from figure 5, since it means that when the transformer voltage is zero, the voltage at point 1 is 2.8 V; since the Schmitt trigger changes state at the threshold values of 2.1 V and 3.1 V, we can say that, in spite of the hysteresis, it is only triggered around the zero-crossing point of the transformer waveform (the small deviation from the ideal switching point of exactly 0 V can be eliminated by making R9 variable and using a scope to adjust it to the correct value; in practice, however, this small error is of little significance and does not materially affect the operation of the circuit).

When both inputs of N3 are high (i.e. greater than 3.1 V), the output is low, and since N4 is connected as an inverter, its output will be high, with the result that C2 will be discharged. If point ④ then goes low, since C2 is still uncharged, point ④ will also go low, causing C2 to charge up via R11. The time constant of R11/C2 is 18 ms; shortly before this time is reached the voltage at pin 12 of N3 will have reached the logic '1' threshold and since, at that moment, pin 13 has once more been taken high, the output of N4 is also returned high. Since capacitor C2 is already charged, the voltage across it would continue to rise, but for the clamping diode in N3. The capacitor is rapidly discharged (figure 5 ④), and a new cycle begins.

The signals at points ② and ③ form the clock signals for flip-flops FF1 and FF2. The J-inputs of these flip-flops are connected to points ⑥ and ⑦, where the voltage is determined by the temperature of the iron, whilst the K-inputs are connected to ground. Only when the J-inputs are high can the clock pulses have any effect and change the state of the flip-flops. Since the voltage at point ⑥ is an inverted version of that at point ⑦, when the former goes low the first positive-going edge at point ② will take the Q output of FF1 (point 9) low, causing T2 to turn off and the triac to be triggered. The soldering iron then begins to heat up, so that the voltage at point ⑥ rises until it reaches the trigger threshold of N1. When that happens N1 changes state, taking point ⑥ low and point ⑦ high; the next positive-going pulse at point 3 will take the Q output of FF2 high and reset FF1, thereby taking point ⑥ high and resetting FF2. Thus T2 is turned on and the triac turned off, interrupting the flow of current to the heating element in the iron. The temperature of the iron will fall until the lower threshold value of

Parts list

Resistors:

- R1 = 2k2 1 W
- R2 = 1 M
- R3 = 2k2
- R4 = 22 k
- R5 = 4k7
- R6 = 82 Ω
- R7, R8, R12 = 10 k
- R9, R10 = 33 k
- R11 = 180 k
- R13 = 1 k 1 W
- R14 = 100 Ω
- R15 = 100 k
- P1 = preset potentiometer 10 k
- P2 = potentiometer 100 k linear
- P3 = preset potentiometer 100 k

Capacitors:

- C1 = 470 μ /40 V
- C2 = 100 n
- C3 = 10 μ /10 V
- C4 = 100 n
- C5 = 22 n

Semiconductors:

- D1 = 1N4001
- D2 = 5V6/400 mW
- D3 = LED red
- D4 = LED
- T1 = BC 559C
- T2 = BC 547B
- Tri = 2 A/100 V (or 4 A/400 V)
- IC1 = 3130
- IC2 = 4093
- IC3 = 4027

Miscellaneous:

- transformer 24 V/2 A
- fuse 0.25 A slow blow
- soldering iron with built-in heat sensor, e.g. Antex type CTC or XTC
- soldering stand.

N1 is reached, whereupon a new cycle will begin.

Those phases during which current is fed to the iron (i.e. when the triac is conducting) are indicated by LED D4 lighting up.

The waveforms shown in figure 5 do not exactly coincide with those obtained in practice, since the noise at the inputs of IC1 (which in no way affects the performance of the circuit) has, for the purpose of clarity, been omitted from the diagram.

Construction

Figure 6 shows the track pattern and component overlay of the p.c.b. for the circuit of figure 4.

Constructing the control unit should not present any major problems. Connection points A . . . E marked on the board correspond to those shown in figure 4, and are in fact the holes for connections to the soldering iron.

Figure 7 shows the DIN-plug of the Antex CTC soldering iron with details of the correct pin connections and colour of the leads.

In principle the triac should require no heat sink; however if the circuit is mounted in a small case and the iron is operating under heavy load conditions, then the use of a heat sink is strongly recommended (not to mention ventilating the case). In fact every effort should be made to prevent any rise in the ambient temperature of the circuit, since, as was already mentioned, this will have an adverse effect upon the temperature coefficient of the constant current source.

Figure 6. Track pattern and component layout of the p.c.b. for the circuit of figure 4. (EPS 9952).

Figure 7. The Antex soldering iron is fitted with a DIN-plug. Pins A . . . E correspond to connection points in the circuit of figure 4. Pin E is shown as a ground point and connects to the metal body of the iron.

On no account should the 0 V rail of the control circuit be connected to mains earth, although it is permissible to earth a metal case, if one if used.

Table 1.

| 40 V-Version | |
|--------------|-----------------|
| U_{Tr} | 40 V/1 A |
| R1 | 4k7, 3 W |
| C1 | 470 μ /63 V |
| R13 | 2k2, 3 W |
| T2 | BC546 |

6

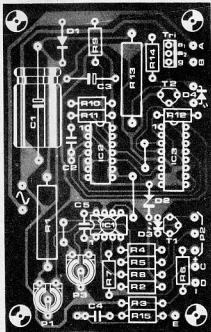

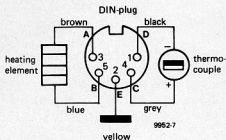

The photo shown on the first page of this article is a prototype model of the Elektor control unit. For exhibition purposes the unit was housed in perspex. The soldering stand shown in this photo is not particularly suited for low power irons, since the contact between the iron and the metal rings leads to considerable heat loss and hence to the iron being switched on and off with excessive frequency. Soldering stands which avoid direct metal-to-metal contact with the iron should be given preference. These can be bought separately from most electronics shops.

Adjustment procedure

The setting up procedure for the control unit is as follows:-

Firstly, with the soldering iron disconnected, the inputs of IC1 are shorted together. The offset voltage is then reduced to a minimum by adjusting P3 until D4 either just lights up or is just

extinguished (depending upon which state it assumes when power is applied). Next, the short is removed and the wiper of P2 is turned fully towards R6 (anticlockwise). The soldering iron is then plugged in and the tip is held against a length of solder. Although solder melts at approx. 189°C (60/40 alloy), at around 185°C it exhibits a 'plastic' consistency. By *very gradually* adjusting P1, it is possible to set the temperature of the iron such that the solder is in this plastic state, just on the point of melting (185°C). P1 should be adjusted in small steps, always allowing the temperature of the iron to stabilise before testing it against the solder and performing another adjustment.

By means of P2, it is then possible to vary the temperature of the iron between 185°C and approx. 400°C. P2 can be calibrated using the following equation:

$$T \approx 185 + \frac{P2}{82} \times 185^\circ\text{C} \quad (P2 \text{ is in } \Omega)$$

In conclusion

As was already mentioned, the prototype model of the control unit was designed for use with the CTC or XTC soldering iron from Antex. However it can also be used with other types of iron, particularly if they are provided with a thermocouple heat sensor. If this is the case, and if the iron operates off 24 V, then it can be connected direct to the Elektor control unit. In the case of an iron with the same operating voltage but which employs a different sort of sensor, the situation is a little more complicated. With a PTC thermistor, D3 and D4 should be omitted, T1 replaced by a wire link between the emitter and collector connections, and the value of R2 altered accordingly. The same procedure holds good for irons incorporating an NTC thermistor, with the exception that R2 and the NTC should be transposed.

In the case of an iron employing a thermocouple and operating from a 40 V supply, the modifications shown in table 1 should be adopted.

The above-described control unit is thus suitable for use with a wide variety of different types of soldering iron, and represents a considerable saving in cost over commercially available models.

The final point worth noting is that the circuit can not only be used to regulate the temperature of soldering irons, but can be adapted for a number of other applications requiring a thermostatic control unit, such as, eg. clothes irons, ovens, central heating etc. ■



FAST NICD CHARGER

Most popular personal radios suffer from high current consumption, so that it is sensible to power them from rechargeable batteries. Unfortunately, with most battery chargers on the market it takes up to 15 hours to recharge batteries. The charger proposed here does it in under an hour.

Most of the smaller NiCd batteries on the market today have sintered electrodes that can withstand fairly high currents. This makes it possible for such batteries with capacities up to about 500 mAh to be recharged to 80% of their capacity within an hour.

The problem with fast charging of NiCd batteries is switching off the charge current at the right time. With these batteries, unlike, for instance, lead-acid batteries, it is not possible to determine this from the charging voltage.

The circuit

The circuit consists of four distinct sections as shown in Fig. 3. In Fig. 3a are the supply section with rectifier, B₁, and 5-V voltage regulator, IC₁, and a Type 4060 timer, IC₄. The sections in Fig. 3b and Fig. 3c are identical to enable the charging of two LR6-size (U7) batteries. It should be noted that batteries cannot be connected in series in a voltage-controlled charger, because the batteries are never fully charged at the same time. Each of the sections in Fig. 3b and Fig. 3c consists of a charging voltage monitor and switch, IC₂ (IC₃), and a Type BD680 darlington, T₁ (T₂), which functions as the source of the charging current.

The supply section is provided with an 'on' indicator, D₁₅. The input comes from a mains transformer with an 8-V, 1.5 A secondary. The rectified voltage is smoothed by C₃. The regulated 5-V output of IC₁ is used as reference voltage and to power IC₄.

The clock in the 4060 operates at a frequency of 2.5 Hz, determined by R₁₀ and C₆. After 2¹³ (= 8192) clock pulses (= about 54 mins) from reset key S₁ being pressed, output Q₁₄ (pin 3) becomes logic high.

The reference voltage for IC₂ and IC₃ is derived from the regulated 5-V output of IC₁ by potential divider R₁-P₁-R₂. The reference voltage is the value of the battery voltage at which the charging process must be terminated: it is invariably 1.5 V.

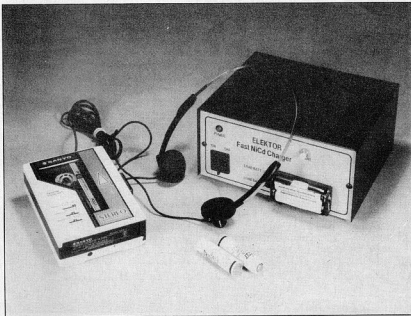

The reference voltage is applied to the inverting input of IC₂ (IC₃) via R₁ (R₄). The battery voltage is applied to the non-inverting input of the opamps. The ICs also function as bistables, which, together with IC₄, are provided by S₁ with a set pulse at the onset of the charging process.

When S₁ is pressed, the inverting input of IC₂ (IC₃) is briefly connected to +8 V via D₅. That is sufficient to switch the output of the opamps to 0 V. If the battery voltage is lower than the reference voltage, the comparator remains in this state and current source T₁ is switched on. A current of about 0.5 A then flows through the battery (batteries) and D₄ (D₈) lights. This LED does not only serve as charging indicator, but, in conjunction with D₃ (D₆), also serves as voltage reference for T₁ (T₂). The magnitude of the charging current is determined by the value of R₈ (R₉).

When the potential across the battery becomes greater than the reference

voltage, the relevant opamp (IC₂ or IC₃) toggles. Its output then becomes logic high and the charging process stops, because no base current can flow in the current source, which therefore switches off. The feedback via R₄ (R₁₅) and D₂ (D₇) maintains the opamp in this state. It can only be reactivated by S₁.

If, because of a disparity between the battery and reference voltages the current source is not switched off, the timer comes into action. After about 54 minutes (see above), output Q₁₄ (pin 3) becomes logic high, which causes the opamps to be reset and thus terminate the charging cycle.

Extra charge

After about 54 minutes, the batteries are charged to something like 80% of their capacity, which is sufficient for their use in the personal radio. Considering that many of such radios draw a current of around 100 mA, the batteries will give

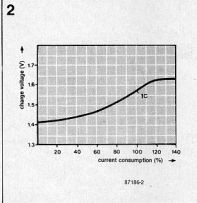
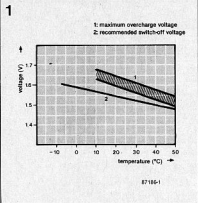
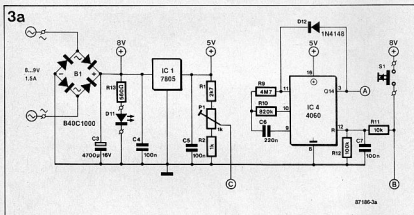

Fig. 1. Recommended switch-off voltage and over-charge voltage pertaining to sintered NiCd cells as a function of ambient temperature during charging. It is not advisable to use fast charging at ambient temperatures below 10° C.

Fig. 2. Typical charging voltage vs charging current (as a percentage of battery capacity) characteristic of sintered NiCd cells for a charging current of IC (=0.5 A for a 500 mAh battery). A charge of about 80% of full capacity is reached when the battery voltage has risen to just above 1.5 V.



about 4 hours playing time. If they had been charged to their full capacity of 500 mAh, they would have afforded 5 hours playing time.

To enable batteries to be charged to their full capacity, a resistor (dashed across the current source in Fig. 3b and Fig. 3c) may be fitted. This resistor allows a small charging current to continue to flow after the current source has switched off. During the fast charge, the resistor is virtually short-circuited by the darlington and is, therefore, of no practical consequence.

For a 'normal' charging current of 45-50 mA, the value of this resistor is 150R and rated at not less than 0.5 W, but 1 W is better. Normally, there is no risk in leaving the batteries on charge via this resistor for days on end. If this happens habitually, however, it is better to give the resistor a value of 220R or even 270R, rated at 0.5 W.

A reasonably charged battery can be kept at that level by giving the shunt resistor a value of 330R.

Finally

Although it was said earlier on that the supply is obtained via a mains transformer, it is also possible to obtain it from a mains adapter that gives an output of 8 V a.c. or d.c. (in the latter case, there is, of course, no need for the rectifier in Fig. 3a). Darlington's T₁ and T₂ require a heat sink.

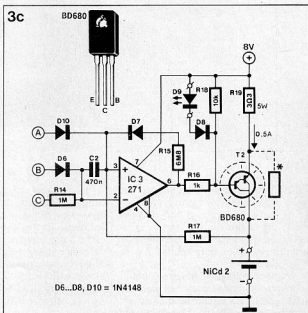
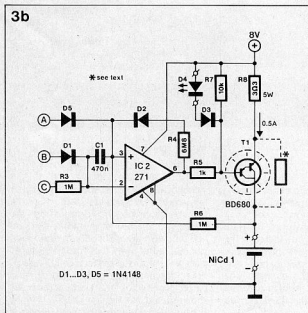

Fig. 3. The circuit diagram of the battery charger: if only one battery is required to be charged at any one time, the section in Fig. 3c may be omitted.

Parts list

Resistors ($\pm 5\%$):

R1 = 2K7
R2; R5; R16 = 1K0
R3; R6; R14; R17 = 1M0
R4; R15 = 6M8
R7; R11; R18 = 10K
R8; R19 = 3R3; 5 W
R9 = 4M7
R10 = 820K
R12 = 100K
R13 = 560R
P1 = 1K0 preset

Capacitors:

C1; C2 = 470n
C3 = 4700 μ ; 16 V
C4; C5; C7 = 100n
C6 = 220n

Semiconductors:

B1 = 840C1000 (40 V; 1 A) (Universal Semiconductor Devices)
D1; D2; D3; D6... D8 incl.; D10; D12 = 1N4148
D4; D9 = red LED
D11 = green LED
IC1 = 7805
IC2; IC3 = TLC271CP (Cricklewood)
IC4 = 4080
T1; T2 = BD680 (Cricklewood)

Miscellaneous:

S1 = miniature SPST switch.
Heat-sink for T1; T2.
PCB Type 87186

4

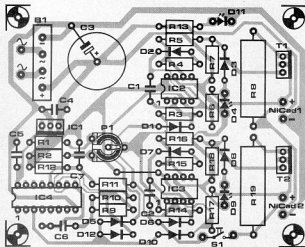

Fig. 4. The printed circuit of the battery charger.

5

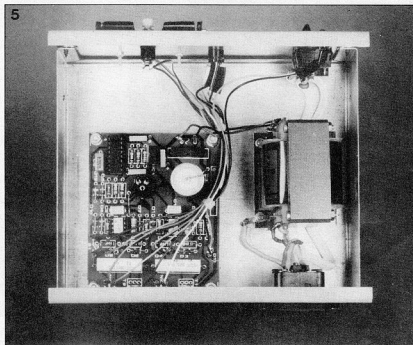

Fig. 5. Top inside view of the prototype of the battery charger.

If there is no need for charging two batteries simultaneously (some personal radios work from one 1.5 V battery), one of the sections in Fig. 3b or Fig. 3c can be omitted. In that case, the input current needs to be only about 0.7 A instead of 1.5 A.

The battery voltage varies from manufacturer to manufacturer, but lies normally around 1.5 V. During the first few charging cycles it is, therefore, recommended to set P1 to 1.5 V. Make sure that the batteries are fully discharged before connecting them to the charger,

and ascertain (with the aid of D4 and D9) when the current sources switch off. The optimum charging period is about 55 minutes. If the current sources switch off after a shorter period, increase the reference voltage slightly. If the reference voltage was originally set too high, the timer will switch off the charger. The ideal situation is that the comparators switch off just before the timer can do so.

In all this, it is assumed that the ambient temperature remains at roughly the same level. At lower temperatures, the charger

switches off slightly sooner; at higher temperatures, somewhat later.

Construction of the charger on the printed-circuit board should present no difficulties. After the board has been populated, it may be fitted, together with the mains transformer (if used), reset switch, lights, on/off switch, and battery connector in a neat enclosure as shown in Fig. 5.

It should be possible to construct the charger for about £15.00 (at UK prices; in other countries, this cost may be quite different).

MICROPROCESSOR-CONTROLLED RADIO SYNTHESIZER — 2

by Peter Topping

This final instalment of the article deals with the construction and setting up of the multi-purpose RF synthesizer. This has been divided in a number of building blocks to allow its use in a large number of applications, from upgrading surplus SW receivers to providing state-of-the-art tuning on modern tunerheads for the VHF FM band.

It will have been evident from Part 1 of this article ⁽¹⁾ that the microprocessor-controlled synthesizer is a relatively complex project with many possible configurations and applications. To enable its use with many types of receiver (SW, SW/MW, VHF FM), and to allow the user the choice between three types of display, the synthesizer system is divided in a number of sub-units:

1. Microprocessor board;
2. Keypad;
3. One or more displays (these are not necessarily of the same type);
4. Power supply;
5. Synthesizer board;
6. VHF prescaler board (f_{LO} up to 150 MHz);
7. SW prescaler board (f_{LO} up to 40 MHz).

Items 1, 2, 3 and 4 are fitted in a separate enclosure, while 5 and 6, 5 and 7, or 5 and 6 and 7, are incorporated in the existing receiver. Item 4, the power supply for the microprocessor/display unit, is not discussed here as it assumed that the constructor is capable of building a simple regulated 5 VDC power supply without the need for repeating an application of the 7805. Similarly, the 5 V supply for items 5, 6 and 7 should be relatively simple to obtain from the receiver.

As already noted in Part 1, the supply voltage for the opamp in the synthesizer module (Fig. 3) is governed by the maximum reverse voltage required on the varicap that tunes the local oscillator. Remember that this auxiliary voltage is also applied to varicaps D_1 and D_2 in the RIT circuit, so that it must remain below +10 V. Where +30 V is to be used, make sure that this is **only** applied to C_{11} and IC_2 .

Prescalers

The circuit diagram of the prescaler for SW receivers is shown in Fig. 8. Transistor T_{11} ensures that the local oscillator

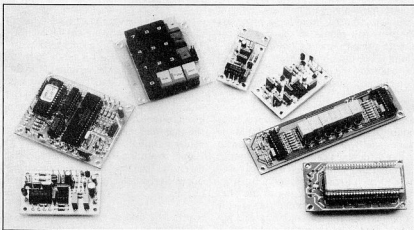

Prototypes of all boards, completed and ready for wiring. From the left to the right: Synthesizer, microprocessor, keyboard, SW prescaler, VHF prescaler, LED display, LCD display.

in the receiver is not excessively loaded, and at the same time functions as an amplifier/digital driver for divider IC_{12} . The prescaler has a divide-by-five and a divide-by-ten output (refer to Table 1 in Part 1). It can handle LO input signals of up to about 40 MHz, and has a sensitivity of 150 mV_{rms} at 20 MHz. The maximum usable frequency can be increased to over 60 MHz by using a Type 74F90 in position IC_{12} .

The VHF prescaler is a rather more elaborate circuit — see Fig. 9. Ahead of the divide-by-ten ECL counter, IC_{12} , is a two-stage direct-coupled wideband amplifier, T_8 - T_9 . Although the SP8660 is stated to have a TTL- and CMOS compatible open collector output, some interfacing and filtering of the signal is required before it can be applied to the LO input of the MCI45157 (IC_1). Sensitivity of the VHF prescaler decreases from 30 mV_{rms} at about 100 MHz to 500 mV_{rms} at 190 MHz (note that the latter frequency exceeds the maximum specification of the SP8660). In an experimental set-up, the VHF prescaler was found to have an absolute maximum

Corrigenda to Part 1:

- Pull-up resistor R_{40} (Fig. 4) should be labelled R_{70} .
- The IF offset table in the EPROM starts at 19DBH, not 1E05H.
- R_9 (Fig. 3) is a 3K9 resistor.
- Pin 11 of IC_{11} should be connected to ground.

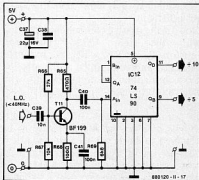

Fig. 8. Circuit diagram of the 40 MHz prescaler with divide-by-five and divide-by-ten outputs for use with SW receivers.

input frequency of 250 MHz. The amplification of T_9 is defined mainly by the value of R_{S8} .

Five modules on one PCB

Printed circuit board 880120 (Fig. 10) is quite large because it holds the following sub-units (the associated circuit diagrams are given in parentheses):

- Synthesizer (Fig. 3);
- Microprocessor circuit (Fig. 4);
- Keyboard (in upper left-hand corner of Fig. 4);
- SW prescaler (Fig. 8);
- VHF prescaler (Fig. 9).

With the exception of the section for the keyboard, the PCB is double-sided, but not through-plated. The prescaler and synthesizer boards have large pretinned copper earth planes at the component side to prevent stray radiation.

Commence the construction with carefully cutting the large PCB in six to obtain the previously mentioned boards.

Microprocessor board:

The construction of the microprocessor board is not difficult, but should be done strictly in the order given below to avoid difficulties caused by the absence of through-plating (this was not used here to keep the cost of the PCB within limits). Through-contacting of tracks at the component and solder side of the board is effected by soldering the relevant component terminals or pins of IC sockets at both sides of the board.

Start by fitting the 40-way socket for the microprocessor, IC1. A normal IC socket will not be very useful here since it does not allow soldering to tracks at the component side. Two 20-way terminal strips, or a 40-way wire-wrap socket, are suitable alternatives. A similar way of mounting applies to the other three ICs: first mount the socket for the 74HC373 (IC2), then that for the 74HC00 (IC3) and, lastly, that for the EPROM 27C64 (IC4). Constructors with lots of confidence may, of course, solder all ICs direct on to the board, but this will make their removal at later stage very difficult.

Now fit the passive components, starting with the eight 100 k Ω pull-down resistors R_{19} to R_{26} , which are mounted vertically and commoned at the top side by a horizontal running ground wire (alternatively, use a 9-pin SIL resistor array).

In a number of cases, one or both terminals of a component will have to be soldered at both sides of the board to connect tracks. At the component side, some terminals run quite close to, or over, tracks they should not be connected to. To avoid short-circuits, bend the wires accurately, and mount components slightly above the board surface. The mounting of the 4 diodes and the quartz

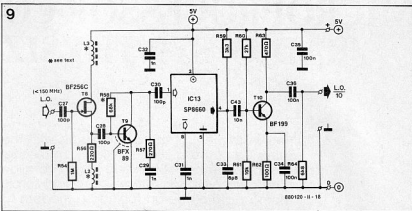

Fig. 9. The VHF prescaler is composed of a two-stage preamplifier, an ECL decade counter and a digital interface.

crystal (two possible enclosure sizes are allowed) should not present problems.

The connection of the microprocessor-board to the keyboard is made in a 10-way flat ribbon cable, terminated in 10-way press-on (IDC) sockets at either end for pushing on associated headers on the boards. The pinning of the connection is given in Table 3. All other connections to the microprocessor board are made via solder terminals.

Before mounting the ICs in their sockets, carefully inspect the microprocessor board for solder faults and/or short-circuits.

Synthesizer board:

No through-contacting is required here, with the exception of the three solder terminals for the ground connections (supply, I/O input, I/O TUNE output). The

board is relatively densely populated, but its completion should not present problems. A few hints, though: do not use a socket for IC1; the type indication printed on varicap diodes D1-D2 should face the quartz crystal.

SW prescaler board:

Solder IC2 direct on to the board. The terminals for the input and output coax cables are soldered at both sides of the PCB.

VHF prescaler board:

First, wind L_2 and L_3 as 6 turns of 0.2 mm dia (SWG36) enamelled copper wire through 3 mm long ferrite beads. When mounting these chokes, make sure that the copper wire can not touch the earth plane at the component side of the PCB. Next, mount the soldering ter-

| ***** | | ***** | |
|--------------------------------------------|------|-----------------|------------------------|
| * The IF offset is selected according to * | | * * | |
| * the required band, then placed in "P" * | | * * | |
| ***** | | ***** | |
| 1986 C0 19 34 | I F0 | JSR BAND | FIND BAND |
| 1989 48 | | LSLA | X2 |
| 198A B7 22 | | STA W1 | |
| 198C 48 | | LSLA | X4 |
| 198D BB 22 | | ADD W1 | TIMES 6 AND ADD 5 |
| 198F AB 05 | | ADD #5 | TO REACH LAST DIGIT |
| 19C1 B7 23 | | STA W2 | OF SELECTED IF |
| 19C3 A6 06 | | LDA #6 | |
| 19C5 B7 2A | | STA COUNT | |
| 19C7 BE 23 | LP6 | LDA W2 | |
| 19C9 06 19 DB | | LDA IFS, X | TRANSFER |
| 19CC 3A 23 | | DEC W2 | SELECTED |
| 19CE BE 2A | | LDA COUNT | INTERMEDIATE FREQUENCY |
| 19D0 E7 15 | | STA P-1, X | INTO P |
| 19D2 3A 2A | | DEC COUNT | |
| 19D4 26 F1 | | BNE LP6 | DONE? |
| 19D6 AE 16 | | LDX #P | SET-UP POINTER |
| 19D8 BF 2C | | STX | |
| 19DA 81 | | RTS | |
| 19DB 00 00 00 04 05 05 | IFS | FCB 0,0,0,4,5,5 | 455 KHZ SW/MHz |
| 19E1 00 00 00 04 06 08 | | FCB 0,0,0,4,6,8 | 468 " " |
| 19E7 00 00 00 04 07 00 | | FCB 0,0,0,4,7,0 | 470 " " |
| 19E0 00 01 00 07 00 00 | | FCB 0,1,0,7,0,0 | +10.7 MHZ SW (EXT/5) |
| 19F3 09 09 08 09 03 00 | | FCB 9,9,8,9,3,0 | -10.7 " FM (EXT/10) |
| 19F9 00 00 00 00 00 00 | | FCB 0,0,0,0,0,0 | 0 " " |
| 19FF 09 09 09 09 09 03 | | FCB 9,9,9,9,9,3 | -70 KHZ " " |
| 1A05 00 00 01 00 07 00 | | FCB 0,0,1,0,7,0 | +10.7 MHZ " " |

Extract of the source listing used for assembling the machine code in EPROM ICs. This routine reads the band selection switches and calculates the IF offset with the aid of the data between addresses 19DB and 1A0A.

Fig. 10. Component mounting plan for pretinned, double-sided, not through-plated PCB 880120-1. This should be cut to separate (from top to bottom): keyboard PCB, microprocessor PCB, synthesizer PCB, VHF prescaler (lower left) and SW prescaler (lower right).

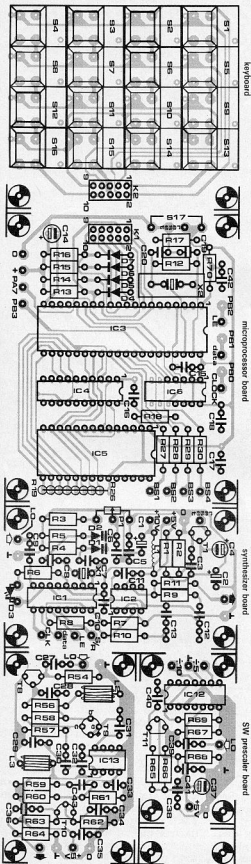

11

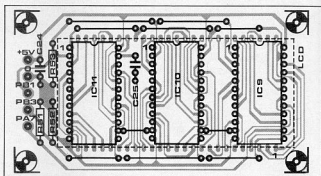

Fig. 11. Track layout and component mounting plan of the static LC display board. READ THE TEXT BEFORE FITTING THE LCD.

12

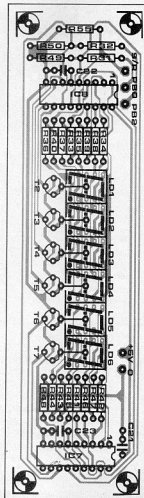

Fig. 12. Track layout and component mounting plan of the LED display board.

Table 3.

pin assignment on keyboard connectors:

| K1 | K2 | Signal |
|-----|------|--------|
| 1 | 1 | KB7 |
| 2 | 2 | KB6 |
| 3 | 3 | KB0 |
| 4 | 4 | KB1 |
| 5&6 | 5&6 | KB5 |
| 7 | 7 | KB2 |
| 8 | 8&10 | KB4 |
| 9 | 9 | KB3 |

Parts list

KEYBOARD

S1...S16 incl. = Digitast momentary action key (ITT Shadow or ITW).
K2 = 10-way straight header; 2 x 5 pins in 0.1 in raster.

MICROPROCESSOR BOARD

Resistors ($\pm 5\%$):

R12 = 10M
R13...R17 incl. = 10K
R18...R30 incl. = 100K
R70 = 27K

Capacitors:

C14 = 10 μ ; 16 V; radial
C15...C18 incl. = 100n
C19; C20 = 39p
C42 = 10n

Semiconductors:

D4...D7 incl. = 1N4148
IC3 = MC146805E2 (Motorola);

IC4 = 74HC373

IC5 = programmed EPROM Type 27C64;

IC6 = 74HC00

Miscellaneous:

K1 = 10-way straight header; 2 x 5 pins in 0.1 in raster.
X2 = quartz crystal 1 MHz.
S17 = externally fitted push-to-make button.
S18...S21 incl. = externally fitted miniature toggle switch.

SYNTHESIZER BOARD

Resistors ($\pm 5\%$):

R1 = 10K
R2 = 100K
R3 = 68K
R4; R5 = 1M Ω
R6 = 270R
R7 = 24K
R8 = 39K
R9 = 3K9
R10 = 2K7
R11 = 6K8
P1 = externally fitted 100K linear potentiometer.
See text.

Capacitors:

C1 = 47 μ ; 35 V; tantalum bead
C2; C3 = not fitted
C4 = 2 μ 2; 16 V; radial

C5; C9 = 100n
C8; C10; C11 = 10n
C7; C6 = 1n Ω ceramic
C12; C13 = 1 μ 0; MKT

Semiconductors:

D1; D2 = KV1235Z (Toko product; available from Cirkut plc or Bonex Ltd. These diodes are sometimes supplied in sets of three matched devices held together as a Chocobreak[®] unit).
D3 = externally fitted red LED
IC1 = MC145157 (Motorola)
IC2 = 741
T1 = BC547B

Inductor:

L1 = 22 μ H axial choke.

Miscellaneous:

X1 = 10 MHz quartz crystal.

VHF PRESCALER

Resistors ($\pm 5\%$):

R64 = 1M Ω
R66 = 220R
R57 = 270R
R58 = 68K
R59 = 3K3
R60 = 27K
R61 = 10K
R62 = 100R
R63 = 470R
R64 = 6K8

Capacitors:

C27; C28; C30 = 100p
C29; C31; C32 = 1n Ω
C33 = 6p8
C34; C35; C36 = 100n
C43 = 10n

Inductors:

L2; L3 = 6 turns 0.2 mm dia enamelled copper wire through a 3 mm long ferrite bead.

Semiconductors:

IC13 = SP8860 (Plessey);
T6 = BF256C
T9 = BFX89 (Cricklewood)
T10 = BF199

Resistors ($\pm 5\%$):

R65 = 470R
R66 = 27K
R67 = 10K
R68 = 100R
R69 = 6K8

Capacitors:

C37 = 22 μ ; 16 V; radial
C38; C40; C41 = 100n
C39 = 10n

Semiconductors:

IC12 = 74LS90
T11 = BF199

ALL OF THE ABOVE CIRCUITS ARE FITTED ON THE RELEVANT SUB-PCBs CUT OFF FROM TYPE 880120-1

STATIC LC DISPLAY BOARD

Resistors ($\pm 5\%$):

R61; R52; R63 = 100K

Capacitors:

C24 = 100n
C25 = 10n

Semiconductors:

IC8; IC10; IC11 = MC144115P (Motorola)
LCD = general-purpose 6-digit static liquid crystal display, e.g. Type LTD229-R12 (Philips Components), RS587-327

Miscellaneous:

PCB Type 880120-2

LED DISPLAY BOARD

Resistors ($\pm 5\%$):

R31; R32 = 27K
R49; R50; R55 = 100K
R33...R48 incl. = 270R
* See text.

Capacitors:

C21 = 100n
C22; C23 = 22n

Semiconductors:

IC7; IC8 = MC14499P (Motorola)
LD1...LD6 incl. = HD1107R (Siemens);
ElectroValue 0784 33603 or 061 432 4945)
T2...T7 incl. = BC182

Miscellaneous:

S22 = externally fitted miniature SPST switch (see text).
PCB Type 880120-3

minals (three ground posts are soldered at both sides of the PCB). Proceed with fitting the resistors and capacitors, followed by the transistors. Lastly, solder the prescaler chip direct on to the board.

Keyboard:

The construction of this unit is so simple as obviate the need for further discussion.

Multiplexed display board:

As already stated in Part 1, this unit is 10.50 elektor india october 1988

not supported by a ready-made PCB because the multiplexed LC display is a relatively hard to obtain item. Constructors in possession of the Type 4200-365-920 from Hamlin may mount it on a piece of Veroboard, together with the three passive components and the display controller Type MC145000. As there are relatively few connections to be made (compare the circuit diagram, Fig. 7, to that of the static LC display unit, Fig. 6), the actual construction should not prove too difficult. When using the

multiplexed display, be sure to fit it in a metal enclosure to reduce stray radiation.

LED and static LC display

The single-sided printed circuit board for the static LC display is shown in Fig. 11. This is a very compact unit, whose construction is commenced with the mounting of the ten wire links, followed by the three 24-way IC sockets, five passive components and five

soldering pins.

THE DASHED LINES ON THE COMPONENT MOUNTING PLAN INDICATE THAT THE LIQUID CRYSTAL DISPLAY IS MOUNTED AT THE TRACK SIDE OF THE BOARD. BE EXTREMELY CAREFUL HANDLING THE FRAGILE GLASS DEVICE, AND MAKE SURE THAT IT IS FITTED THE RIGHT WAY AROUND.

Pin 1 of the LCD is practically opposite pin 13 of IC₉, as shown on the component overlay. Hold the display slightly oblique in clear light to make the individual segments visible. Turn the display so that the row of decimal points is horizontal and towards you. Pin 1 of the unit is the leftmost terminal, below the lowest horizontal segment of the first (most-significant) digit. The above description is given because not all 6-digit LC displays have a marker for pin 1.

The socket for the 50-pin LC display can be made from the terminal strips of a 40-way and a 14- or 16-way IC socket. Mount these strips slightly above the board surface to enable soldering to the tracks. Then fit the display carefully, observing the previously mentioned orientation. Be sure that the display is supplied with side pins, so that it can be mounted as an integrated circuit.

Constructors opting for a 7-segment LED display should have little difficulty completing the printed circuit board shown in Fig. 12. First fit the 6 wire links, then the sockets for the displays (cut off 14-way IC sockets to make your own 10-way types).

Initial test

Make all the necessary connections between the completed microprocessor board, synthesizer board, keyboard and the static LCD or LED display. The prescalers are not required as yet. Do not forget to temporarily connect the reset switch and band/I.F. switches to the microprocessor board, and be sure to observe the terminal designations printed on the PCBs. Note that the LED display board is driven with the ϕ signal provided by the synthesizer board via an optional switch, S₂₂ (see Part 1).

It is recommended to power all the units from a single 5 V supply. Where a separate 10 V supply is not available, connect the +10 V terminal on the synthesizer board to +5 V also.

Apply power. The display should be cleared after operating the MODE button. If this does not happen, press the reset key. Verify that RESET of the microprocessor is logic high. Now type a few numbers on the keyboard, and check that these are displayed correctly. Read up the section on the use of the command keys (Part 1), and check that the

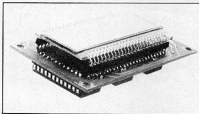

Side view of the completed static LC display board, showing that the controller chips and the glass LC display are mounted at opposite sides of the board.

special mode indication symbols appear on the display (decimal points, dash on the LED type and small square on the LC type). The OUT of 10CK LED should light because the local oscillator (and prescaler) is yet missing from the phase-locked loop.

It can safely be assumed that the microprocessor board, keypad and display function correctly if the above test checks out.

In the receiver

Since the microprocessor-controlled radio synthesizer is a general-purpose design, users must rely on their own knowledge and experience when it comes to incorporating the prescaler and synthesizer modules in an existing receiver. A few general observations can be made, though:

1. Be sure to understand how the receiver is actually tuned. If it has mechanical tuning (inductor/variable capacitor), this must be replaced with a varicap system as shown in Fig. 1 in Part 1. For SW receivers, it is recommended to use a modern varicap with a relatively high C_{max}/C_{min} ratio, e.g. Toko's KV1235 or KV1236, to enable using a low control voltage (max. 10 V or 25 V respectively). If the local oscillator inductor provides a DC path to ground for the varicap, and C is not required for defining the tuning rate, then C and R can be omitted.

It is strongly recommended to first convert the receiver as shown, then use an external potentiometer to find out what range of the tuning voltage is required to ensure the receiver's original frequency coverage, and only then attempt to bias the varicap by the synthesizer's output loop filter.

If the receiver already has electronic tuning, i.e., if it is tuned by a single tuning voltage obtained from a potentiometer or a channel preset unit, simply measure the tuning voltage range, and connect the tuning voltage input to the output of the loop filter via a short length of screened cable. Dimension the supply to opamp IC₂ as explained above.

2. The local oscillator in the receiver must be 'tapped' to provide the input signal for the relevant prescaler. It is important to ensure that this signal is of

sufficient amplitude, but every care should be taken to prevent the oscillator being significantly loaded. Most transistorized receivers have a buffer stage between the local oscillator and the mixer. The input of the prescaler is then conveniently connected to a low-impedance point at the buffer output by means of a short length of thin coaxial cable. Coupling out of the LO signal via a tank inductor in the oscillator is not recommended as it will degrade the quality (Q) factor — this may limit the tuning range, and reduce the oscillator output power to the mixer.

For some SW and MW applications, it is possible to omit the 40 MHz prescaler and drive the MC145157 direct with the oscillator signal. This can, however, only be done when the LO signal has a frequency lower than 15 MHz, and an amplitude of at least 500 mV. The author developed and debugged his prototype of the synthesizer using a simple LW/MW/SW radio based on the Type TDA1083 one-chip receiver IC. This operated satisfactorily with pin 5 AC-coupled direct to the MC145157 with no buffering.

For VHF FM applications, the prescaler used (Fig. 9) is sufficiently sensitive to enable driving it by relatively small amplitudes of the LO signal. For instance, in the case of the LP1186 tunerhead, the LO signal can be taken from the emitter of oscillator transistor BF195 (near the centre of the PCB).

It is strongly recommended to check that the prescaler used (whether the SW or VHF type, or both) functions correctly. Temporarily fit it in the receiver, near the local oscillator, and measure the output signal frequency (SW: ± 5 or ± 10 ; VHF: ± 10) to verify that it receives enough LO signal, and does not in any way affect the receiver's normal behaviour. Use a 15 MHz oscilloscope to check that the output signal is of digital amplitude ($5 V_{pp}$), and free from spurious pulses and noise, which could point to parasitic oscillation.

Before closing the loop...

Be sure that the following questions are answered in the affirmative before actually connecting the completed synthesizer to the receiver:

- Does the receiver work as before with varicap tuning installed, and can it be tuned by a temporarily fitted potentiometer?
- Is the supply voltage for the active loop filter (IC₂) in accordance with the maximum required tuning voltage, and are the prescaler and synthesizer boards correctly powered?
- Does the prescaler supply a correct output signal at all settings of the receiver tuning?
- Is the band/I.F. setting for the micro-

processor board in accordance with the actual intermediate frequency of the receiver? (consult Table 1 and the technical specification of the receiver).

As a final check, leave the output of the loop filter disconnected from the LO tuning input, and program a frequency within the receiver's tuning range. Connect a voltmeter or a DC-coupled oscilloscope to the loop filter output. As the external potentiometer is operated to tune the radio through this frequency, the filter output should switch from one extreme to another. Until all of the above tests pass, it is not useful to close the loop, as it is then very hard to distinguish the cause of a problem from its effects.

The microprocessor board, keypad, display, and 5 V power supply are housed in a desk-style ABS enclosure. The band/L.F. selection switches are fitted as a 4-way DIP switch block on the sloping front panel.

The connection to the synthesizer board in the receiver is made in a 6-wire cable terminated in a 9-pin D-connector plugged into a mating socket at the rear of the enclosure. The signals carried in this cable are:

- LE, DATA and CLK (from microprocessor to IC);

- S/R (from IC1 to the LED display board);
- RESET (from T1 to the microprocessor);
- ground.

It should be noted that S/R is not required when the static display board is used.

The quartz crystal on the microprocessor board may be replaced with a 1.8432 MHz or 2 MHz type, which is generally less expensive than a 1 MHz type.

The only problems that could be experienced with the synthesizer are instability of the LO frequency and audible reference frequency on the output of the radio. Either of these problems should be resolved by empirically adjusting R7 through R10. R9 and R10 should normally be in the range from 1 kΩ to 10 kΩ, and R7 and R8 in the range from 10 kΩ to 50 kΩ. Accurate values can not be predicted as these depend on factors which vary between oscillators. The most significant of these is the tuning rate expressed in MHz per volt. The values shown in Fig. 3 were used with a dual-conversion shortwave receiver with a tuning rate of about 1 MHz/volt.

If, after adjusting the above resistors,

the reference frequency can still be heard, the tuning rate may need to be reduced by using a smaller valued C (Fig. 1), and adding a fixed capacitor across the oscillator inductor. This will increase the Q of the oscillator and reduce phase noise. If the tuning range becomes too small, it can be restored by switching oscillator inductors. Finally, the prescaler and synthesizer boards installed in the receiver should be fitted in screened metal enclosures.

Reference:

- ⁽¹⁾Microprocessor-controlled radio synthesizer — 1. *Elektron India*, September 1988.

motorphone

It is almost always impossible for a motor cyclist and his passenger to maintain aural contact without dangerous acrobatics. The circuit shown in the figure affords effortless voice contact. The microphone amplifier of post 1 is formed by an amplifier stage T1 followed by a super emitter follower. The DC coupling determines the current through R1 and

the base-emitter voltage of T1. So when one party speaks he hears himself, so that he knows the system is working. Since the two posts are connected in series, the signal generated in post 1 travels through both telephones, so that this 'intercom' needs only one wire between the two posts.

The main function of the supply with T7, T8 and T9 is noise suppression,

whilst at the same time the system is made short-circuit proof. Via R13 and D2 an audible indication of the trafficators is obtained. The interphone posts can be made so small they can be mounted in the crash helmets. The supply is mounted on the machine. The microphones are crystal types.

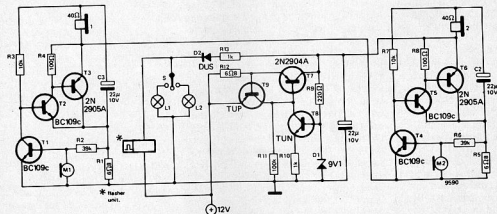

COMPUTER-GENERATED COLOUR TEST CHART

For ATVers and other video enthusiasts in possession of a BBC, Electron or Archimedes computer we have developed a program that generates a test chart with resolution test blocks and selectable foreground and background colours.

Although a computer can not replace a pattern generator for adjustment of convergence or RGB circuits in a modern colour TV, it is eminently suitable as a low-cost means of generating a steady high-resolution picture, which is often required for testing video circuits. One particularly interesting use of the computer as a video generator is linearity and bandwidth alignment of an ATV (amateur television) transmitter. The

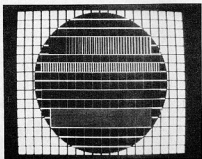

colour output signal of the BBC, Electron and Archimedes computers is of excellent quality, and has more than sufficient bandwidth, so why not do something useful with those complex and expensive video chips? Software alone can do it.

The REM (remark) lines in the listing explain the operation of the program. The colour can be changed by pressing the Z or W key on the keyboard.

```

1 REM ***** COMPUTER-GENERATED TEST CHART FOR BBC-B AND ELECTRON *****
2 REM ***** ELEKTOR ELECTRONICS *****
10 MODE7
20 PRINT"Black can be changed to colour by pressing the Z key"
30 PRINT
40 PRINT"Write can be changed to colour by pressing the W-key"
50 PRINT"PRINT"but not before the test chart is complete"
60 PRINT"PRINT"      PRESS THE SPACEBAR TO BEGIN...."
70 REPEAT
80 UNTIL INKEY(-99)
90 REM --- Interlace OFF ---
100 *TV0,1
110 MODE1
120 VDU 23.1,0:0:0:0:REM --- Cursor OFF ---
130 WC=7:ZX=0
140 PROCcolour
150 PROCvert
160 PROCchor
170 XC=500
180 PROCcircle
190 XL=256
200 lim=1
210 FOR nX=0 TO 255
220   PROCbandwd(7,0,704,127)
230 NEXT
240 XC=192
250 lim=4
260 FOR nX=0 TO 99
270   PROCbandwd(10,7,576,63)
280 NEXT
290 XC=192
300 lim=8
310 FOR nX=0 TO 52
320   PROCbandwd(7,0,384,63)
330 NEXT
340 XL=256
350 FOR lim=12 TO 2 STEP -.185
360   PROCbandwd(10,7,192,127)
370 NEXT
380 REPEAT
390 IF INKEY(-98) THEN ZX=ZX+1
400 IF ZX>=8 THEN ZX=0
410 IF ZX=XC THEN ZX=ZX+1:REM -- foreground colour <> background! --
420 PROCcolour
430 IF INKEY(-34) THEN WX=WX+1
440 IF WX>=8 THEN WX=0
450 IF WX=ZX THEN WX=WX+1:REM -- background <> foreground! --
460 PROCcolour
470 IF INKEY(-113) THEN 1230
480 UNTIL FALSE
500 REM --- draws and fills circle ---
510 REM --- within circle, colour is inverted per dot ---
520 DEFPROCcircle
540 PLOT4,640-RX,S12
550 FOR nX=R-RX TO RX STEP 2
560   YX=500+(R5-RX)*XC*YX
570   nY=XC+140
580   nY=YX+512
590   nY=512-YX

```

```

600   GCOL3,POINT(nX,nY)
610   PLOT4,nX,nY
620   PLOTS,nX,nY
630   GCOL4,POINT(nX,nY)
640   PLOTS,nX,nY
650 NEXT
660 ENDFPROC
680 REM --- draws vertical lines: width is 2 picture lines ---
700 DEFPROCvert
710 nX=62
720 REPEAT
730   FOR nX=0 TO 4 STEP 2
740     PLOT4,nX*n5,0
750     PLOTS,nX*n5,1023
760   NEXT
770   nX=nX+64
780 UNTIL nX>1280
790 ENDFPROC
810 REM --- draws horizontal lines: width is 2 picture lines ---
830 DEFPROCchor
840 nY=62
850 REPEAT
860   FOR nX=0 TO 4 STEP 2
870     PLOT4,0,nY*nX
880     PLOTS,1280,nY*nX
890   NEXT
900   nY=nY+64
910 UNTIL nY>1024
920 ENDFPROC
940 REM --- draws vertical lines at height nY ---
950 REM --- line width is function of nX and limX ---
960 REM --- In logic colours col1X in col2X ---
980 DEFPROCbandwd(col1X,col2X,nX,nY)
990 GCOL0,col1X
1000 PROCblock
1010 GCOL0,col2X
1020 PROCblock
1030 nX=nX+1
1040 ENDFPROC
1050 DEFPROCblock
1060 FOR nX=0 TO lim
1070   PLOT4,nX*nX,nY
1080   PLOTS,nX*n5,nY*nX
1090   nX=nX*n5
1100 NEXT
1110 nX=nX
1120 ENDFPROC
1140 REM --- switching from logic colours to real colours ---
1150 REM --- timed by vertical sync. ---
1160 REM --- Only two colours can be displayed simultaneously ---
1170 DEFPROCcolour
1180 *FX19
1190 VDU19,0,WX,0,0,0
1200 *FX19
1210 VDU19,7,ZX,0,0,0
1220 ENDFPROC
1230 VDU22,1,1:0:0:0:REM --- Cursor ON ---
1240 CL:END

```

sine-square-triangle generator

Unlike the more usual type of function generator, in which the sinusoidal output is derived by shaping a triangular waveform, the basis of this circuit is a Wien-bridge oscillator, which provides a sinusoidal output. The square and triangular waveforms are then derived from this.

The Wien-bridge oscillator is built around CMOS NAND-gates N1 to N4, and amplitude stabilization is provided by T1, D1 and D2. These diodes should, if possible, be a matched pair, for minimum distortion. The frequency adjustment potentiometer P1 should also be a good quality stereo potentiometer with the tracks matched to within 5%. The preset R3 provides adjustment for minimum distortion and if matched components are used for D1,

also varies with frequency. In practice the amplitude variation is relatively unimportant, since the generator will usually be used with a millivoltmeter or oscilloscope and the output can be monitored. Adjustment of the triangle amplitude is provided by P3.

As the CMOS gates cannot drive very low load impedances an output buffer amplifier is provided, which greatly increases the usefulness of the generator. The amplifier is capable of driving loads of $4\ \Omega$ or greater, which makes it particularly useful for loud-speaker testing. If the generator is likely to be used to generate square-waves at low frequencies (less than 100 Hz) it may be worth increasing the value of C15 to make the top of the square wave flatter. Quiescent current

adjustment is provided by P4 and this should be set to about 50 mA. P5 controls the output amplitude. As the impedances around the CMOS circuits are fairly high the generator should be mounted in a screened metal box to avoid interference pickup. If a mains power supply is used this should be screened from the rest of the circuit to avoid hum pickup. For optimum results at high frequencies C_a (8p2) and C_b (33 p) can be added; note that these components are not shown on the layout for the p.c. board.

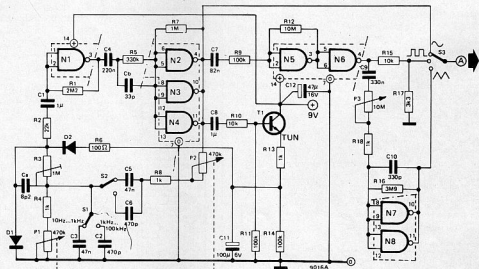

N1 ... N4 = CD4011 = IC1
 N5 ... N8 = CD4011 = IC2
 D1 ... D2 = 1N4148

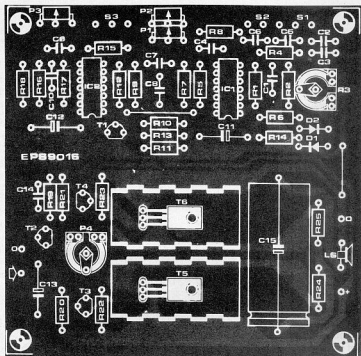

D2 and P1 the total harmonic distortion should be less than 0.5%.

The output of the Wien-bridge oscillator is fed into N5, which is biased into its linear region and operates as an amplifier. N5 and N6 together amplify and clip the oscillator output to give a square waveform. The duty-cycle of the waveform is somewhat dependent on the threshold voltages of N5 and N6, but it is close to 50%.

The output of N6 is fed into an integrator constructed around N7 and N8, which integrates the square wave to give a triangular waveform. The amplitude of the triangular waveform is, of course, frequency dependent, and since the integrator is not perfect the linearity

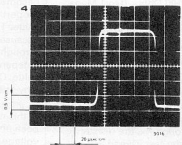
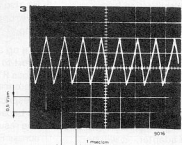
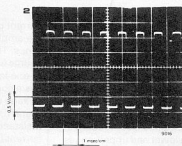
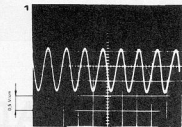
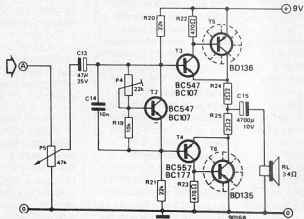

OHM-ADAPTER

Resistance measurement is a common feature of every multimeter. Just a simple zero adjustment is all that it requires to start the resistance measurement. However, in almost all types of multimeters it is difficult to obtain a clear reading in the lower and upper ranges. This happens mainly due to the logarithmic nature of dial calibration in the resistance range.

The Ohm-Adapter circuit presented here is meant for removing this defect. The multimeter to be used with this adapter must have a 0 to 1V range, or at least a 0 to 2 V or 0 to 3 V range of voltage measurement. With the adapter, it will be possible to read resistance values from 0 to 10 Ohms, 0 to 100 Ohms, 0 to 1 Mega Ohms and 0 to 10 Mega Ohms without any problem.

The Measuring Principle

The measuring principle is very simple, as shown in figure 1. A constant current source sends its current through Rx, the resistance under test. Due to the constant current, the voltage drop across the resistor is always proportional to its Ohms value. The voltage is further amplified by the op amp A and fed to the multimeter for measurement.

Circuit Principle

Figure 2 shows the circuit principle in more detailed form. IC1 is the constant

current generator and IC2 is the amplifier, both are op amps. The constant current source functions as follows: at one input of the op amp lies a constant reference voltage u . In the feedback branch, we have the resistance under test. The current I also flows over the fixed resistance R1. The voltage developed across R1 also appears at the inverting input of the op amp.

The op amp now makes an effort to make this voltage across R1, equal to the reference voltage u . This is valid irrespective of the value of Rx because R1 is constant. The result is that the voltage across R1 always remains equal to u and in doing this, the voltage across Rx becomes always proportional to its ohms value. This must happen because the current flowing through Rx is constant and independent of its ohms value. Ohm's Law tells us why this happens.

In this manner, we have been able to obtain a voltage value which is proportional to the ohms value of Rx. Unfortunately this voltage cannot be connected directly to the multimeter, because of the presence of u also at the output of the first op amp. The output of the first op amp is made up of the reference voltage u plus the voltage across Rx. We must now have a way of removing the effect of

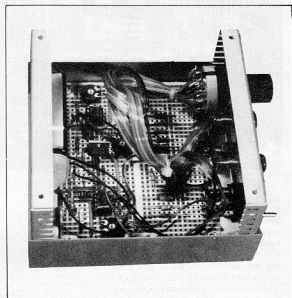

voltage u , before feeding the voltage to multimeter.

This task is given to the second op amp stage made of IC2, which is connected as a differential amplifier. This differential amplifier amplifies the difference between the two input voltages – one of which is the output of IC1 connected through the voltage divider R2' and R3'. The second input is u , the reference voltage connected through R2/R3 voltage divider. As long as the ratio R2/R3 is same as R2'/R3', the difference voltage is proportional to the voltage across Rx. The ratio R3/R2 decides the amplification factor of IC2 and thus we get an amplified voltage at the output of IC2 which is still

proportional to the voltage across Rx. R2 should preferably, be equal to R2' and R3 equal to R3'.

The Practical Circuit:

The detailed diagram of the circuit of the "Ohms Adapter" is shown in figure 3. Though the circuit of figure 3 looks more complicated compared to that in figure 2, the basic principle of operation is same.

The power supply here is a 9V battery pack. S1 is used to connect/disconnect the power supply. IC1 in this circuit is not the same as of IC of figure 2, this IC is an adjustable voltage regulator, which sets the reference voltage u to a value of 4.75 Volts. The

second stage is IC2 which does the function of IC1 in figure 2. This is the constant current generator.

Resistances R4, R5, R6, R7 are selected through switch S2. These are used to decide the constant current that will flow through the test resistance. This must change with the range selected. R4 gives a constant current of 10 mA, while the resistance R7 gives 0.1 microamp. Through

selection of these four resistances, we can select four different measuring ranges, as described earlier. Transistor T1 is used to avoid overloading of IC2 by the current flowing through the resistance under test.

After the constant current source, comes the op amp IC3 which serves to amplify the output voltage proportional to R_x . The resistances R8 and R9 can be compared to the resistances R2 and R2' of figure 2. Resistances R12 and R13, and the pair R10 and R11 correspond to R3 and R3' in figure 2. The correlation is direct.

Selection of either R12 or R13 and R10 or R11 through the range selector switch S2 changes the factor of amplification. This factor is 10 for range A and B, where as it has to be reduced to 1 for the higher ranges C and D.

At the output of IC3 we have a resistance R14 and multimeter M with parallel diode array of D1, D2 and D3. The resistance R14 and the diodes serve as protection for the meter when there is no resistance connected at R_x . The diodes do not allow the voltage across the meter to rise above 2v. In the case where R_x is absent, the output voltage of IC3 can rise to 9V.

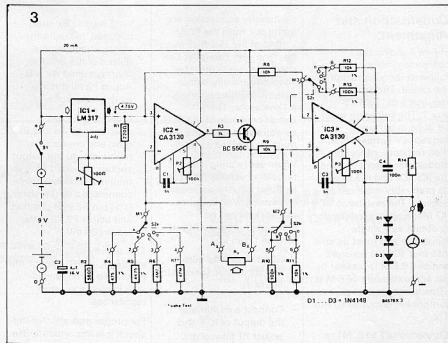
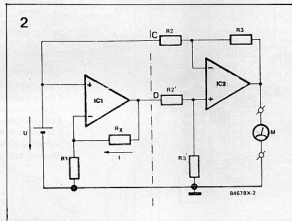
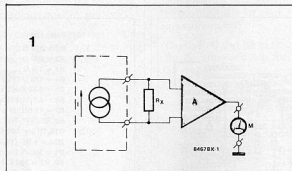

Figure 1:

Block schematic diagram of the ohms - adaptor, in the most simplified form.

Figure 2:

The principle of working of the ohms - adaptor, with all important components.

Figure 3:

The detailed working circuit diagram of the ohms - adaptor, with four measuring ranges selectable through switch S2. This switch is a four position switch with three banks of switching contacts.

4

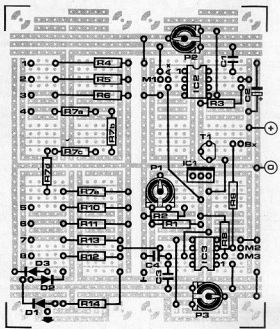

Construction and Alignment.

Figure 4 shows the component layout to be followed for construction of the circuit. The entire circuit requires a SELEX PCB of size 2. The soldering must be done in our usual sequence – jumpers first, then resistors, capacitors, diodes, transistors and then the ICs. IC2 and IC3 should be preferably mounted on Sockets. The resistance R7 (47 Mega ohms) is difficult to obtain as a single resistance and must be split into four 10 M Ω resistors and one 6.8 M Ω resistor to get approximately 46.8 M Ω . This is shown in the component layout as R7a to R7c.

Connections 1 to 8, M1 to M3 and 0, + and the

multimeter connection are going out from the PCB. Wiring of the switches must be done very carefully. The complete circuit must be checked carefully before assembling the same into an enclosure. The component side of the PCB as well as the soldering side must be checked carefully.

When every thing is found to be in order, the PCB can be fitted into the enclosure and wiring with switches and sockets can be completed. Alignment can now be taken up.

- Short circuit Ax output and Bx output. (Shown in figure 4).
- Connect a multimeter to the output of IC 1 and adjust P1 till you get 4.75V at this point.

Parts List:

- R1 = 220 Ω
- R2 = 560 Ω
- R3 = 1 K Ω
- R4 = 475 Ω (1%)
- R5 = 4.75 K Ω (1%)
- R6 = 4.7 M Ω (1% or 5%)
- R7 = 47 M Ω (1% or 5%)
- R8, R9, R11, R12 = 10 K Ω (1%)
- R10, R13 = 100 K Ω (1%)
- R14 = 1 K Ω (1%)
- P1 = 100 Ω Trimpot
- P2, P3 = 100 K Ω Trimpots
- C1, C3 = 1 nF
- C2 = 4.7 μ F / 16 V
- C4 = 100 nF
- D1, D2, D3 = 1N 4148
- T1 = BC 550 C
- IC 1 = LM 317
- IC2, IC3 = CA 3130

Other parts:

- 1 SELEX PCB Size 2 (80 x 100 mm)
- 1 Rotary switch with (3 x 4 position)
- 1 Toggle switch
- 4 Banana plug sockets (3 Black, 1 Red)
- 1 Suitable enclosure.
- Soldering pins
- Hook up wire etc.

Figure 4:
Component layout for the circuit diagram of figure 3. SELEX PCB size 2 is necessary.

- With Ax and Bx short circuited, measure the voltage between the output of IC1 and the short circuited Ax & Bx. Adjust P2 till it reads exactly zero volts.
- Connect a known resistance to Ax and Bx now, and connect the multimeter to the output sockets provided for the multimeter. If you have connected a 68 Ω resistor, (1%) put S2 in B position and adjust P3 till meter reads 680 mV.

The alignment is now complete, check also for the remaining three ranges with known accurate resistances.

For proper operation of the circuit it is important to use 1% tolerance resistances

where ever specified. If it becomes impossible to obtain 1% resistors, you compromise for 5% resistors.

After your adapter comes into fully working condition, you can make some more trials with known resistances, using different ranges for the same resistor and see the results, wrong range selection does not damage

the instrument but the readings are not reliable.

If your multimeter has no 1V range but has only 2V or 3V range, there are two possibilities:

1. Use only half or one third of the full scale for your measurements.
2. Change R8 and R9 to 5k for 2V range and 3.3k for 3V range.

This allows you to use the full scale for measurement, but you must always divide the indicated value by either 2 or 3 depending on the range you have.

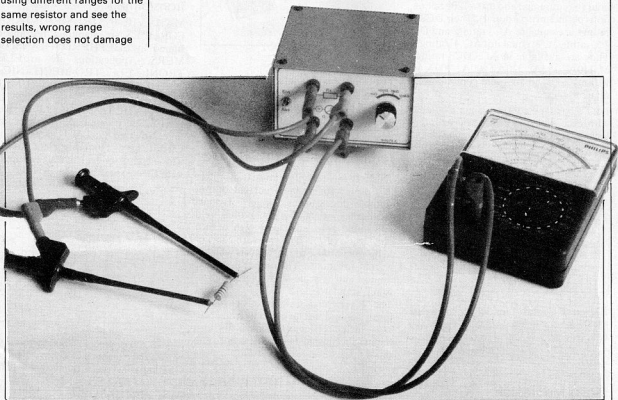

The Digilex-PCB is available!

Price:
Rs. 85.00 + Maharashtra Sales Tax.
Delivery charges extra: Rs. 6.00

Send full amount by DD/MO/PO.

Available from:

precious[®]

ELECTRONICS CORPORATION
Journal Division

52-C, Proctor Road,
 Bombay-400 007
 Ph. 367459, 369478
 Telex (011) 76661 ELEK IN

NEW PRODUCTS • NEW PRODUCTS • N

Contactors

Larsen & Toubro Limited has introduced bar-type contactors which are specially designed for heavy duty under adverse conditions. These contactors, designed series N, are suitable for both AC and DC applications up to 1000 V and can withstand up to 600 operations per hour (Continuous) and up to 1200 operations per hour (occasional). Their DC2/3 ratings are equal to AC3 ratings and DC 4/5 ratings are equal to AC 4 ratings. They are available in AC3/DC3 ratings of 110A, 180A, 320A, 600A, 900A in various NO and NC pole combinations up to 4 poles.

L&T's bar-type contactors are available with accessories like mechanical interlock and a mechanical latch.

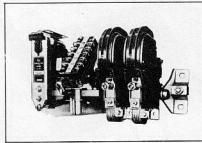

Larsen & Toubro Limited • Switchgear (S) Division • P O Box 278 • Bombay 400 038.

Digital Multimeters

Motwane have recently introduced, three handheld Digital Multimeters; model DM 452, a TRMS $4\frac{1}{2}$ digit and DM 352 & 350, both $3\frac{1}{2}$ digit. These multimeters are heavy duty, top of the line, 7 function, 28 range handheld. LCD readout, with shrouded leads and terminals.

All the three Multimeters have been developed indigenously.

Additional features are AC/DC currents up to 10A, Resistances up to 20M.ohm., continuity, conductance and diode testing, basic accuracy of 0.05% for the DM 452 with frequency response up to 10 KHz and 0.25% for the DM 352 and 350, these instruments, with help of probes can measure temperatures up to 1200°C, AC currents up to 600A, high voltages up to 40 KV AC/DC, frequencies up to 20 KHz and RF up to 200 MHz.

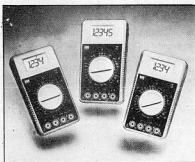

The Motwane Manufacturing Co Pvt. Ltd. • Gyan Ghar • Plot 434A • 14th Road • Khar • Bombay 400 052.

Temperature Transmitter

JNM's two-wire temperature transmitter is a design for 4-20mA current output suitable for various ranges of thermocouples, mV and RTD and has field adjustable zero and span with a turn down ratio of 3:1. The two wire concept helps to minimise the cable costs which is a great advantage. The output is current limited and upscale sensor fault indication is standard.

The RTD version features a built-in lineariser and the specified overall accuracy includes linearisation errors and having the output being linear with the input temperature signal.



The transmitter has a removable PCB assembly housed in a weatherproof NEMA-4 enclosure. This arrangement reduces the installation, commissioning,

maintenance and inventory costs. This unit can be conveniently mounted on a pipe in a horizontal or vertical direction.

J.N. Marshall Pvt. Limited • P.B. No. 1 • Bombay - Pune Road • Kasarwadi • Pune-411 034.

Transformers

MAHAVIR INSTRUMENT TRANSFORMERS are manufactured and designed by SHEPHERD TRANSFORMERS. Applications are in ELECTRONIC ELECTRO-MECHANICAL AND ELECTRICAL INSTRUMENT EQUIPMENTS.

'MAHAVIR' Transformers are tested as per I.S. Specification for resistance, Voltage, No Load, On Load Open and Short Circuit, H.V. Humidity Heat Run etc. These transformers can also be supplied with Electro Static shield.

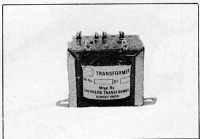

M/s. Shepherd Transformers • Nityanand Nagar • Off Link Bridge • Ghatkopar (West) • Bombay-400 086.

Fasteners

FTC offer a very wide range of fasteners to suit every requirement. Enquiries may be forwarded to.

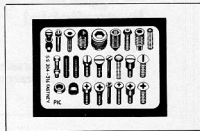

Forged & Turned Components • Marine House • Shop No F • 11-A, Navroji Hill Road • 93 Dr Maheshwari Road • P.B. No 5153 • Chinch Bunder • Bombay-400 009.

NEW PRODUCTS • NEW PRODUCTS • N

Z8 Microcomputer Has On-Board Eprom

ARGATE BZ-APRIL 1987-SGS has extended the popular Z8 microcomputer family with the introduction of the Z86E11, a complete single-chip microcomputer containing a powerful CPU, RAM, serial and parallel I/O ports, two counter/timers and a 4K UV EPROM. The Z86E11 can be configured as a stand-alone microcomputer, as a traditional microprocessor that manages up to 120 k bytes of external memory or as a processor element in parallel processing systems.

The Z86E11 contains a 144-byte RAM, organised as four I/O port registers, 16 control and status registers directly or indirectly via an 8-bit address field. In addition, the register file can be considered as nine 16-register workspaces and individual registers within the selected workspace can be addressed via a short 4-bit addressing mode. The workspace organisation leads to compact programs and also simplifies context switching during interrupt and subroutine calls.

The 4 K x 8 on-board EPROM can be programmed in three different ways, first using a conventional EPROM programming procedure, second using the self-programming mode that allows single bytes to be altered during normal program execution, and in addition an autoloading operation using a simple board.

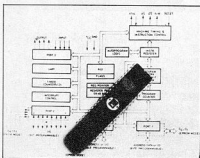

An important feature of the Z86E11 is the programmable readout protection facility which allows users to inhibit external access to proprietary program code. Readout protection is activated by programming two non-volatile transistors. Once set these security locks can be reset only by erasing the entire EPROM array.

M/S. SGS SEMICONDUCTORS (PTE) LTD., • 29, Ang Ko kio Industrial Park 2, • Singapore 2056.

Clock Module

ION clock module F-C1 k/M6 is primarily meant for automobiles. F-C1k/M6 also finds application in UPS systems, emergency lights, battery panels etc.

The display used is 6mm vacuum fluorescent type with green glow. For variety, a transparent acrylic filter of amber, yellow, green, blue or violet can be used to change the display colour to individual taste. Time is shown in hours and minutes in the 12 hours format. An additional feature is the display of month & date in the calendar mode.



The module measures 45(H) x 81 (W) x 14 (D) mm. Four push button switches and a casing are required to complete the clock. Wiring and operating instructions are provided with every piece. To save the car battery from current drain, the display is connected through the ignition switch so that it glows only when the car engine is on.

PROMOTION, • B1k # 4, Flr # 1, • 10, Subash Cross Lane, • Bombay 400 057.

Push Buttons & Indicators

Efficient Engineering have developed the Series 34 Lighted Push Buttons and indicators with rectangular bezel to DIN Standard 48 x 24 mm.

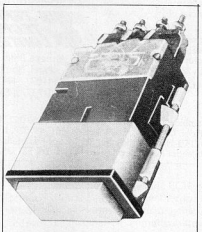

Two independent lamp circuits and one or two pole SPDT Self cleaning and snap acting microswitches, momentary or maintained action or any combination, offer 100% redundancy and a comprehensive functional range as shown.

Such comprehensive range, aesthetic look and ample provision for engraving on front face make these Lighted Push Buttons and Indicators ideally suitable for process Control Instrumentation, Supervisory remote Control Systems, Data Acquisition and Control Systems, Sequencing Logic Controls, Hierarchy Controls and Turn key Instrumentation.

M/s. SAI ELECTRONICS, A Div. of Starh & Allied Industries)

• Thakor Estate, Kurla Kirol road, • Vidyavihar (West), • Bombay 400 086. • Phone : 5136601/5131219.

Voltmeters Etc.

MECO manufactures a range of Portable Instruments for measuring various Electrical Parameters like Amps, Volts, Watts, Power Factor, Frequency, etc.,. Instruments are made in Moving Iron type, Moving Coil type, Moving Coil type, Moving Coil Transducer type & Electrodynamic type. The complete body is moulded from bakelite and the movement is placed in a separate compartment making it completely dust proof. Instrument conforms to BSS & ISS specification and is available in both Industrial Grade Accuracy & Precision Grade Accuracy.

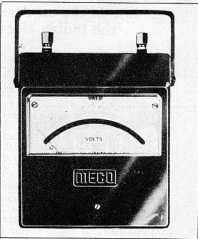

MECO INSTRUMENTS PVT. LTD.
• Bharat Industrial Estate, • T.J. Road, Sewree, • Bombay 400 015. • Phone: 4137423, 4132435, 4137253, • Telex: 11 7101 MECO IN.

NEW PRODUCTS • NEW PRODUCTS • N

Desoldering Station

Zevac Auslotsysteme GMBH, (WEST GERMANY) manufacturers desoldering tools, desoldering station and machines, Zevac Tools are sturdy and designed for high efficiency, ALS desoldering stations consist of vacuum unit desoldering iron and stand, controlled by a foot-switch with 220/24 Volts-supply. PVSG-60 is a desoldering system with an integrated vacuum transducer mounted on the soldering iron handle with a finger operated control to enable complete single handed operation with a supply of 220 or 24 Volts. Zevac Desoldering machines are used for desoldering standard integrated components, multilead connectors as well as chips, capacitors, flatpacks etc.



M/s. Arun Electronics Pvt. Ltd. • 2 E, Court Chambers • 35 New Marine Lines • Bombay 40 020. Tel: 252160/259207.

Digital Multimeter

Ledtron Electronics has introduced autoranging Digital Multimeter Model DT 860A using latest American LSI Technology. Its unique features are autoranging/manual mode, memory for relative measurements, transistor HFE/diode check, datahold, razor sharp LCD with automatic range/function display,

10-ohm range for in circuit resistance measurements etc. It can measure DC/AC voltage up to 1000 V/750 V, DC/AC current up to 15 A, resistance upto 20 megohm and audible continuity check by buzzer. It is housed in compact, portable high impact plastic case with till stand for table top as well as field applications.

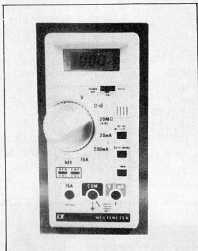

Ledtron Electronic • 170 Lohar Chawl. • Bombay-400 002.

Preset Counters

Micronix offers a range of Digital preset counters for counting and controlling applications. The counters find applications in Machine tools, Pharmaceuticals and food processing industries, Press operations, process control panels, plastic and rubber moulding industries, automobile industries etc.

These counters use CMOS technology. Modular construction makes servicing very easy. The presetting is done through a set of Thumbwheel switches. The actual count is displayed on a 0.5 inch seven segment LED display. It accepts a variety of input sensors such as proximity switch, microswitch or optical sensors.

It gives a set of changeover contacts for control applications. These counters are

housed in DIN standard panel-mountable enclosures. Working voltages are user selectable.



M/s. Micronix • D-74, Angol Industrial Estate, • Udyam bag • Belgaum • Karnataka-590 008.

Temperature Controller

The ARTECH series 101 Temperature Controller is a simple, rugged and accurate instrument which can find applications in all area of Temperature Control. The unit is fully solid state, selectivity using integrated Circuits. The circuitry can withstand normal machine vibration without adverse effects. Automatic cold junction protection, lead resistance compensation and open sensor protection are standard features. The dimensions are suited for flush panel mounting in a 92 x 92 mm cutout as per DIN 43700.

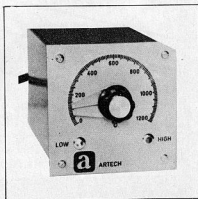

Artech Labs • A-3 Udyog Sadan No. 3 • Central Road • MIDC • Andheri (East) • Bombay 400 093.

CORRECTIONS

Multi-function frequency meter January 1988 p 1.41

The PRIME circuit, which is used for measuring large time intervals, has been connected the wrong way around.

- Pin 6 of IC₂ should be connected to pin 9 of IC₁, not pin 5.
- Pin 2 of IC₂ should be connected to pin 5 of IC₁, not pin 9.

The relevant connections between IC₁ and R₁₂ on the PCB are readily swapped — the two tracks immediately next to IC₁ are cut and then connected crossways.

advertisers' index

| | |
|-----------------------------|-------|
| ABC ELECTRONICS | 10.08 |
| ADVANCED VIDEO LAB | 10.68 |
| BALAJI ENGINEERING | 10.68 |
| BHARAT ELECTRONICS | 10.15 |
| BINATONE | 10.19 |
| COMTECH | 10.12 |
| CROTECH | 10.10 |
| DYNALOG MICRO | 10.11 |
| DYNATRON ELECTRONICS | 10.66 |
| ECONOMY ELECTRONICS | 10.04 |
| ELTEK BOOKS-N-KITS | 10.06 |
| ESKAY AGENCIES | 10.06 |
| ESQUIRE | 10.20 |
| EXCEL | 10.10 |
| G. S. ELECTRONICS | 10.08 |
| TEAP | 10.68 |
| INDIAN TELEPHONE | 10.13 |
| LEADER ELECTRONICS | 10.12 |
| LEDTRON ELECTRONICS | 10.04 |
| MECO INSTRUMENTS | 10.67 |
| NEW AGE ELECTRONICS | 10.67 |
| N. J. INTERNATIONAL | 10.06 |
| OSWAL ELECTRONICS | 10.12 |
| PACIFIC ELECTRONICS | 10.65 |
| PLASTART | 10.08 |
| PRECIOUS | 10.71 |
| RAJPRI ELECTRONICS | 10.08 |
| ROLAND ELECTRONICS | 10.67 |
| SIEMENS | 10.09 |
| SILICON AIDS | 10.16 |
| SMJ ELECTRONICS | 10.02 |
| TANTIA ELECTRONICS | 10.66 |
| TELEPHONE RADIO IND. | 10.04 |
| UNLIMITED ELECTRONICS | 10.16 |
| VASAVI ELECTRONICS | 10.10 |
| VISHA ELECTRONICS | 10.07 |
| ZENITH | 10.61 |



Subscription Order

Name

| | | | | | | | | | | | | | | | | | | | |
|--|--|--|--|--|--|--|--|--|--|--|--|--|--|--|--|--|--|--|--|
| | | | | | | | | | | | | | | | | | | | |
|--|--|--|--|--|--|--|--|--|--|--|--|--|--|--|--|--|--|--|--|

Address

| | | | | | | | | | | | | | | | | | | | |
|--|--|--|--|--|--|--|--|--|--|--|--|--|--|--|--|--|--|--|--|
| | | | | | | | | | | | | | | | | | | | |
|--|--|--|--|--|--|--|--|--|--|--|--|--|--|--|--|--|--|--|--|

Pin Code

| | | | | | | | | | | | | | | | | | | | |
|--|--|--|--|--|--|--|--|--|--|--|--|--|--|--|--|--|--|--|--|
| | | | | | | | | | | | | | | | | | | | |
|--|--|--|--|--|--|--|--|--|--|--|--|--|--|--|--|--|--|--|--|

DO IT YOURSELF

THE

JUNIOR COMPUTER

BOOK

LEARN-BUILD-PROGRAM

the practical introduction
to a powerful system

Price
Rs. 50.00
Available at
all leading
book shops.

The Junior Computer book is for anyone wishing to become familiar with microcomputers, this book gives the opportunity to build and program a personal computer at a very reasonable cost.

The Indian reprint comes to you from

elektor Books

Send full payment by
M.O./I.P.O./D.D. No Cheque Please.
Packing & Postage free

to: **elektor ELECTRONICS PVT Ltd.**
52-C, Proctor Road, Grant Road (E),
Bombay-400 007.

